

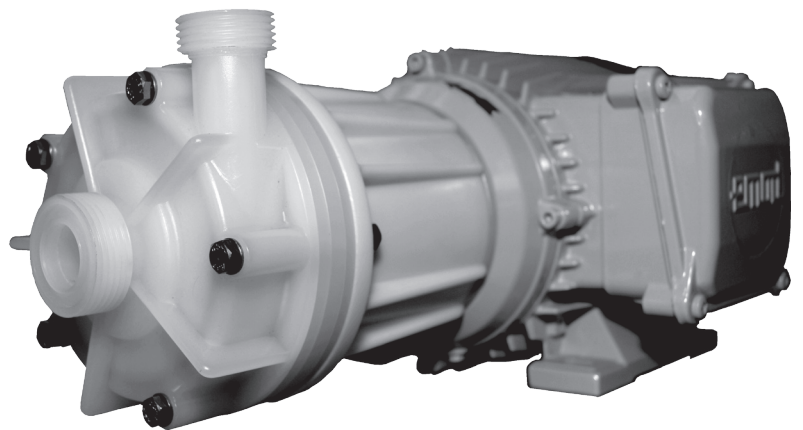

**SCHMITT**  
Kreiselpumpen

**chemical resistant pumps  
for corrosive and highly pure media**

# **Operating manual Servicing Assembly**



## **P Pump Series**

**normal priming,  
magnetically coupled  
impeller-type peripheral pumps**

**materials: PVDF**

## General instructions

This operating manual contains instructions which must be followed during set-up, operation and servicing of the pumps. For this reason, the manual must always be read before set-up and initial operation by the fitter as well as the specialist staff/operator responsible. **It must be available at the unit's application site.**

The staff used for operation, servicing, inspection and set-up must have the qualifications appropriate for these jobs. Area of authority, responsibility and monitoring of the staff must be regulated in detail by the operator. The operator must ensure that the contents of the operating manual have been completely understood by staff and are always followed.

**Non-observance of the instructions can result both in a hazard for the environment and personal hazard, as well as in destruction or damage to the pump or unit.**

Notes in this operating manual, existing national accident prevention regulations and any internal working, company and safety regulations set up by the user must be heeded.

Work may always only be carried out when the pump is at a standstill. Pumps that convey hazardous media must be decontaminated. Before they are restarted, the regulations governing initial operation must be heeded.

The centrifugal pumps have been designed for a pumping medium temperature of **0 to +60 °C**.

**Strong magnetic fields in the magnetic coupling represent a risk for the wearers of pacemakers. Such people must keep away from the pumps.**

## Installing the pump

The pump must be set up in a horizontal position at the designated position. Block pumps are attached without torsion and aligned on a foundation or base plate using the motor bases.

## Relocating pipelines

Before a **SCHMITT pump** is set up, make sure the connection pipes have been laid optimally and professionally. Unfavourable pipe cross-sections or incorrect routing leads to a reduction in performance, or even damage!

**The centrifugal pumps have been designed for a maximum overall pressure of 6 bar at 20°C. Pressure surges are not permitted!**

The nominal widths of the pipelines and the installed fittings have to be designed the same size or larger than the nominal widths of the pumps. Suction pipes should be kept as short as possible. Sharp elbows must be avoided, particularly upstream from the pump's suction muff. Pipelines must be connected to the pump in such a way that there is no force acting on the pump (e.g. offset and weight or expansion when hot liquids are pumped). Use compensators or flexible pipe pieces even when connecting steel pipes.

## Operation

Prevent solids and sludge from being sucked in. **Peripheral impeller-type centrifugal pumps are not suitable for solids or soiling.** If necessary, overflow weirs, filters or strainers must be installed in the suction pipe. Make sure that these do not get blocked, however, otherwise the pump will cavitate. This will quickly lead to damage, particularly to the plain bearings.

**Caution: People with pacemakers must not set up, service or operate magnetic pumps.**

If there is not enough pumping medium or the valve is closed too far (<12 l/min) the pump will run dry. There will be an impermissible increase in temperature. The pump may only be used together with a suitable flow monitoring device. Flow monitoring must correspond at least to a functional fault rate FFR 2 in line with standard EN 13463-6. **The permissible minimum and maximum flow rates can be found in the leaflet.**

Unit-related conditions must be taken into account (e.g. pipeline layouts).

## Installation / Commissioning

Series: P, Sizes 130

Materials: PVDF

Pumps of this series are normal priming, i.e. the pumping medium has to run into the pump.

The inlet is axially in the centre of the pump housing, the standard outlet is tangentially on the right, leading upwards.

The pumps are not equipped with gliding ring seals, rather they have low-maintenance hydrodynamic plain bearings. These are made of different materials depending on the application. If the pump runs dry, the plain bearings heat up, which can lead to damage to the bearings and the pump parts.

**For this reason, never let the pump run dry - not even when checking the motor's direction of rotation!**

After the pump has been set up in the designated place and the suction and pressure pipes have been connected accordingly, the pump is flooded. The pipes and the pump must always be bled. Care must be taken that the connected pipes are airtight.

Before the motor is connected to the local power supply, voltage must be checked against the motor's type plate.

The connection must comply with the requirements of VDE 0100 and those of the local electricity supply companies.

Check the direction of rotation (e.g. at the fan vane of the electric motor) indicated by an arrow on the pump by applying a brief current pulse. The pump must be switched on against **the opened slide on the pressure side.** Then close the slide as far as necessary until the required quantity or operating point has been reached.

Do not operate the pump against slides closed on the pressure side. Excessive heating of the medium inside the pump can lead to damage to the plain bearings or pump parts.

**Throttling on the suction side is not permitted.** This results in cavitation; pumping capacity decreases, damage occurs to the pump parts.

Pumps may only be used for the media and operating conditions specified in the order. In the event of any damage caused by non-observance of this, we cannot accept any liability, as set out in our Terms of Delivery.

Operation at excess rotation speed (frequency converter) is only permissible up to mains frequency according to the technical data.

Series: P, Sizes 130  
Materials: PVDF

Before dismantling work starts, the pump has to be secured in such a way that it cannot be switched on. The pump housing must have cooled to the ambient temperature, be depressurised and empty.

If the pump has been operated with media that are hazardous to health and the environment, it must be cleaned carefully. The resulting pollutants must be disposed of properly.

## Dismantling

Parts 51 and 52 are not rotationally symmetrical. To avoid later problems during reassembly, we recommend marking the parts from the outside e.g. using an Edding pen before dismantling them (alignment to the motor flange).

After loosening the pump housing bolts (27-3), remove the pump housing (06) and pump housing insert (51), then pull out the impeller (04), the backplate insert (52) and the backplate together.

If the outer magnet bell (07) has to be removed, loosen the hexagon socket bolt (09) first. There is an opening for this on the underside of the flange (01). This opening is also used for pulling the bell off the motor shaft. The outer magnets in the bell are only damaged if the pump has been run with the impeller blocked for a long time (noise = low hum). Eddy current formation causes an increase in temperature of the outer magnets and loss of transmission torque.

## Replacing wearing parts

The rings (13v) and (10h) are shrunk into the pump housing insert (51) or the backplate (05) under the influence of heat and should only be replaced in the factory if necessary. Screw off the mouthring on the impeller (12v, right-hand thread) and the mouthring (11h, left-hand thread) and screw the new parts on as far as they will go, but only hand-tight. The wearing parts and seals should be replaced every 2 years or after 3/10 mm wear.

Series: P, Sizes 130  
Materials: PVDF

## Mounting the outer magnet bell

Push the bell onto the motor shaft until the given point "C" is reached (see sketch). Tighten the hexagon socket bolt (09).

## Mounting the pump parts

First put the impeller (04), backplate insert (52) and backplate (05) together outside the pump, then allow this assembly to glide carefully into the flange (01) so that the rear plain bearing (10h/11h) does not become damaged.

**CAUTION: Strong magnetic forces!**

Turn the gap in the channel (bridge) of the backplate insert to about 2 o'clock. Now put the pump housing insert and pump housing in place accordingly and fix in place using the pump housing bolts.

**Observe the torques of the pump housings bolts 27-3.**

**They are 2-3 Nm for the P 130 / PVDF.**

**CAUTION: Functional problem if tightening torques deviate.**

Establish smooth running by turning the vane of the motor fan.

When ordering spare parts, always quote the 8-digit part number of the pump (see type plate)! When starting to use the pump again, follow the instructions valid for initial operation.

# Part description for the P pump series

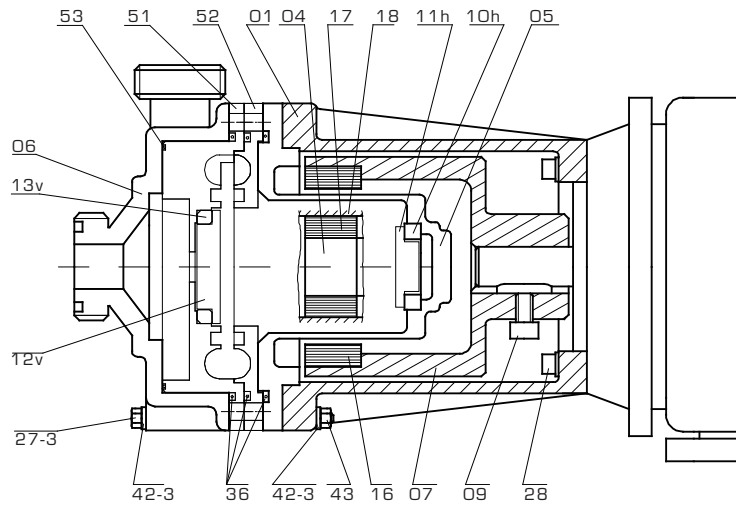

Part no.	Description	Standard	Materials	
			Standard	Optional
O1	Flange	PP		
O4/17	Impeller with inner magnet + magnet cover	PVDF		
18		PVDF		
11h	Mouthring (left-hand thread)	PTFE		
12v	Mouthring (right-hand thread)	PTFE		
O5	Backplate + ring	PVDF		
10h		Ceramic		
O6	Pump housing	PVDF		
36	Pump housing seal	FKM**		FEP or EPDM
07	Outer magnet support with magnet + cylinder bolt			
16/09				
27-3	Hexagon bolt	A4		
28	Cylinder bolt	A4		
42-3	Washer	A4		
43	Hexagon nut	A4		
51	Pump housing insert + ring	PVDF		
13v		Ceramic		
52	Backplate insert	PVDF		
53	Sealing ring	FKM**		

\*\*FKM = e.g. Viton®

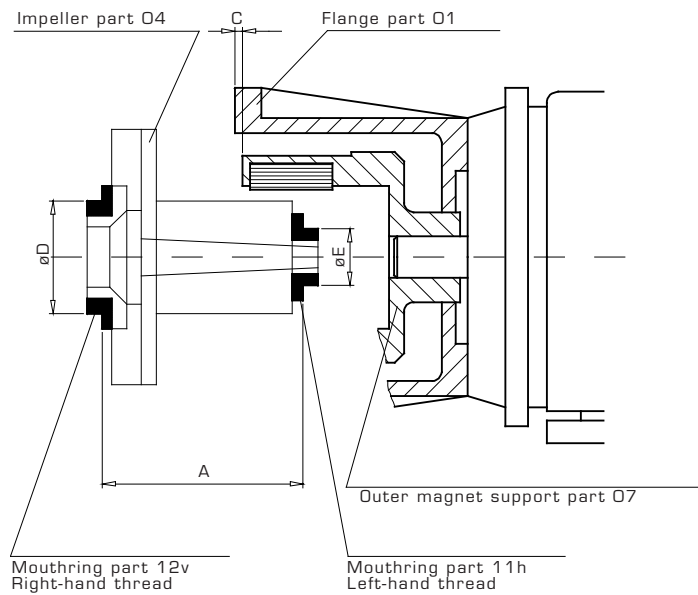

Dimensions when new

Type	A	C	D	E
P 130	76,1	3,1	33,8	19,8

# Characteristic curves of the P pump series

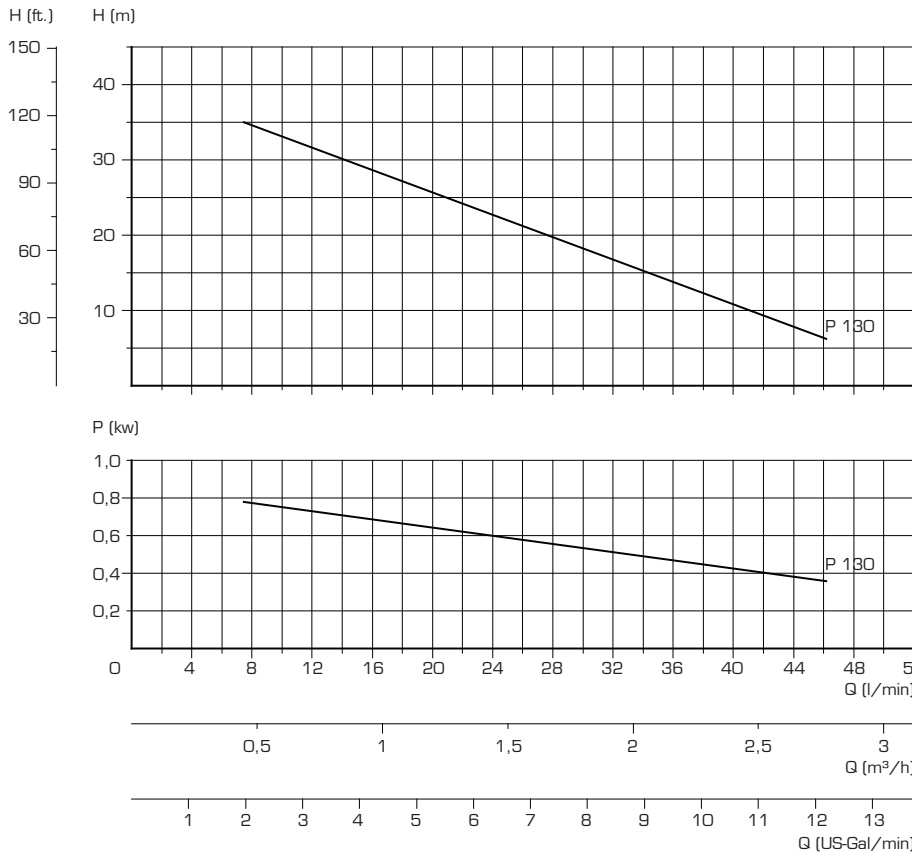

Series  
P 130

Motor power  
P 130      1,10 kw

Characteristic curves measured with water at 20°C and 2900 rpm (50 Hz).

# Specifications for the P pump series

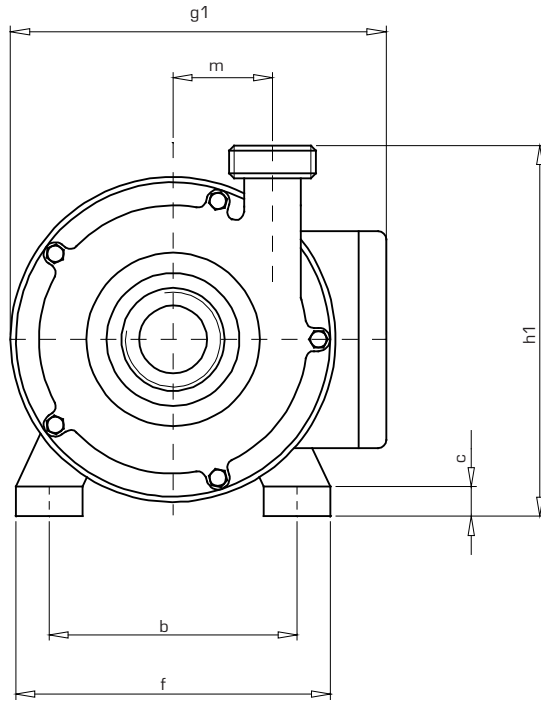

Type	h	h1	l	l1	l2	g	g1	p	a	b	e	f	c	ø s	m	Suction conn.		Pressure conn.		Weight kg
																DN	Outer thread	DN	Outer thread	
P 130	80	159	410	174	216	157	215	159	100	125	125	160	11	10	42	20	G1¼"	15	G1"	12,7

The motor dimensions refer to the PVDF - three-phase version - standard motors.

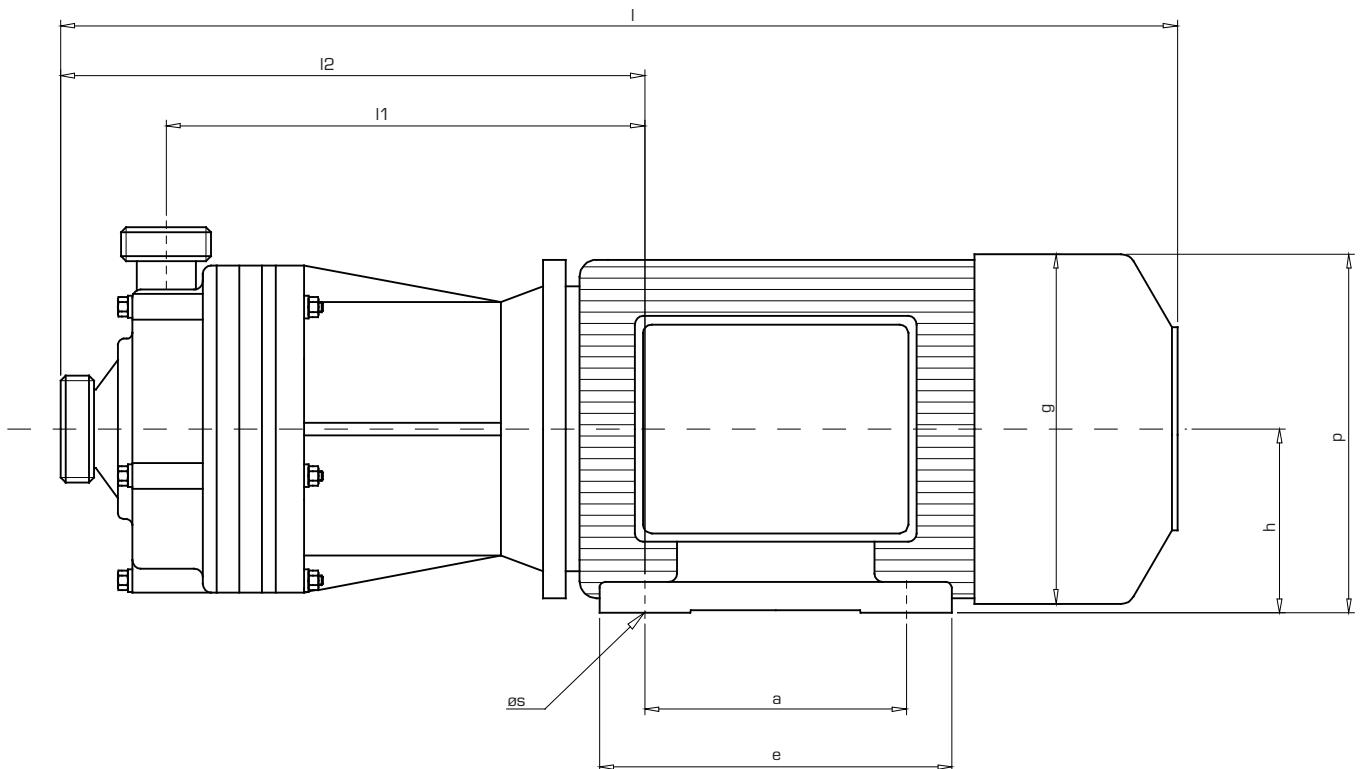

## General

**SCHMITT centrifugal pumps** comply with the high demands made on them in terms of design and production.

Proper assembly and treatment as recommended in this operating manual are the prerequisites for problem-free long-term operation.

For this reason, this manual must be read carefully before assembly and initial operation of the pumps as well as during servicing work, and the advice it contains must always be followed. Every SCHMITT centrifugal pump has a part number on it with the numbers necessary for any correspondence and reserve deliveries later. Please always quote this number.

## Warranty

Warranty is granted according to our General Terms and Conditions.

Always inform us immediately of any damage that occurs during the warranty period, this is the only way you can be sure of making a warranty claim.

We can only accept warranty for the materials and versions recommended if the operating conditions and liquids pumped match the specifications given in the order.

If there are any changes in concentration, temperature of the pumped media or hydraulic data, we have to be consulted. We will then check whether the pump we delivered can be used for the changed operating conditions. In the event of any damage caused by non-observance of this, we cannot accept any liability, as set out in our Terms of Delivery.

Our written agreement has to be obtained for modification and servicing work during the warranty period, as otherwise the warranty shall be null and void.

Only use qualified staff for this work, or return the complete pump to our factory for examination or repair.

We cannot accept warranty for pump parts that are subject to premature wear on account of their material properties or type of use, such as mechanical seals, seals and the like.

For accessory parts that we do not manufacture ourselves, we can only accept warranty claims within the scope granted to us by the respective sub-supplier.