

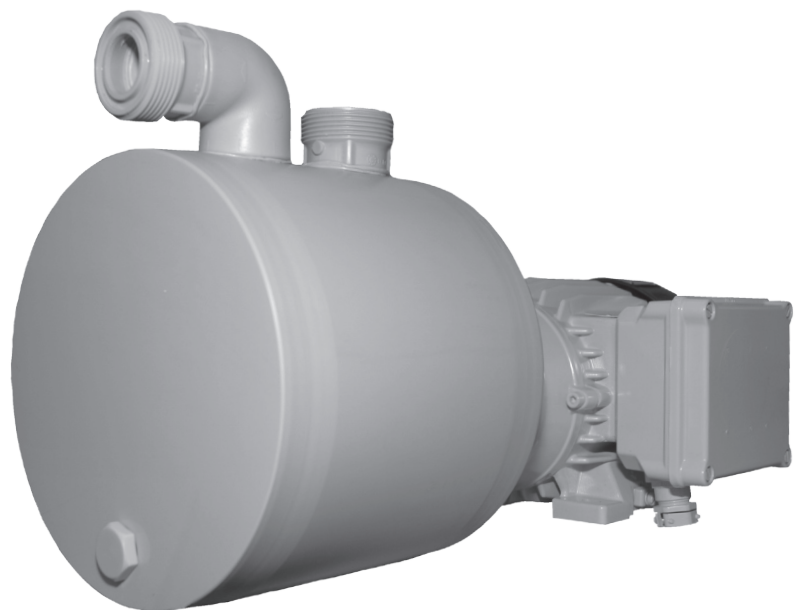

SCHMITT
Kreiselpumpen

**chemical resistant pumps
for corrosive and highly pure media**

Operating Maintenance Assembly Instruction



S Pump Series

**self-priming centrifugal pumps
with a single mechanical seal**

**materials: housing: PP or PVC
other parts made of PVDF**

General instructions

The present operating instructions must be complied with when installing, operating and servicing the pumps. This is the reason why these instructions must be read by the operator, the assembling personnel and all the other specialists/operators before installing and commissioning the pump. These instructions must be readily available for consultation at the site of installation.

The personnel in charge of operation, maintenance, inspection and assembly must be qualified to carry out this work. The scope of the personnel's responsibility, competence and supervision must be precisely defined by the management. The management must also ensure that the operating instructions are fully understood and complied with by the personnel.

Non-compliance with the present instructions may not only cause damage to the environment and be dangerous for the personnel but may also result in the total destruction of or damage to the pump or the installation.

The present instructions, current national measures for accident prevention, and all internal works-, operating- and safety instructions specified by the user are to be complied with.

The work is to be carried out on inactive pumps. Pumps which are used with hazardous materials must be decontaminated. Before started such pumps up again, the instructions for initial commissioning are to be complied with.

Installing the pump

The pump is to be installed horizontally at the chosen operating site. Monobloc pumps are installed stress-free in situ (on the ground or the bottom plate) with the help of the feet.

Relocating pipelines

Prior to installing a **SCHMITT centrifugal pump**, please ensure the very best and appropriate arrangement of the connecting tubes. Inappropriate tube cross section and erroneous arrangement can result in lost performance, and even damage.

The pipeline's nominal width and the incorporated armature must be of equal width or wider than the pump's nominal width. Suction lines must be as short as possible. Sharp bends must be avoided, especially before the pump's suction connection pieces. Pipelines are to be connected to the pump in such a manner that no forces act on the pump (e.g. mismatch, weight or dilation when hot liquids are being pumped). Use compensators or flexible connection pieces. This also applies in the event of metal pipelines.

Operation

Avoid pumping solids and mud. If necessary, overflow protection, filters or screen cages are to be incorporated into the suction line. Please be careful that these do not become blocked since the pump will otherwise cavitate. This can result in damage, particularly to the plain bearings.

Pump Series: S 115 - S 170
Housing materials: PVC or PP
Pump material: PVDF

Pumps, which belong to the present pump series, are **self-priming**.

The axial intake is located centrally above the housing, with the output leading vertically to the top.

Pumps belonging to this pump series are fitted with a single-acting, internal axial face seal which is flushed and cooled by the feeding liquid. It is made of various different materials, depending on its use. Due to the contact pressure required by the sealing surfaces, high temperatures are very rapidly reached in the event of dry-running which may result in damage to the sealing parts.

Never allow the pump to run dry - this also applies to rotational direction tests of the motor!

Install the pumps at the chosen site and fill the housing. Connect the suction and pressure lines in accordance with instructions. Please make sure that the lines and the pump have been properly bled. Also ensure that all the connected lines are absolutely watertight.

Before connecting the motor to the power supply, please match the voltage with the indications on the motor.; check explosion-proof motors for their protection class.

The connection must comply with VDE regulations and those of the local electricity board.

Test the pump`s rotational direction by giving it a brief current pulse. Switch the pump on by activating the closed slide valve on its pressure side. Subsequently, open the slide valve to reach the desired flowing or working point.

Do not operate the pump against the closed, pressure-side slide valve.

Suction-side throttling is not permitted. This results in cavitation; performance levels fall off and damage may be caused to pump parts and axial face seals.

Only use the pumps for the pumping mediums and operating conditions specified in the order form. As stated in our General Terms of Sale, we shall not be held liable, for any damage which resulted from non-compliance with the present operating instructions.

To prevent flowing out of the lines and the pump housing after switching off the pump, fit the suction pipe with a check valve.

Pump Series: S 115 - S 170

Before dismantling the pumps, secure them so as to ensure that they cannot be switched on. The pump housing must have reached ambient temperature, must be unpressurized and empty. Carefully clean the pump when this is used for hazardous and environmentally dangerous feeding media. Pollutants from this operation are to be disposed of in the appropriate manner.

Dismantling of version A + B

Unscrew the housing screws (27-3) and remove the housing (06). Unscrew the cap (04-3) and the locking bolt (04-1). Hold the shaft-extension (02) between the pump and the motor tight with a fork wrench and unscrew the impeller (04/03). All parts have right-hand thread. The impeller is best removed with the use of a ribbon gripper. In version A, the impeller is fitted with a thrust collar (32-1). In version B, the impeller is fitted with a coil-spring (32), a thrust washer (35), a o-ring seal (31) and a rotating seal (30). Remove the cover (05) from the flange (01). A stationary ring (33) and a o-ring seal (34) are to be found in the cover. Push the stationary ring and the o-ring seal out off the cover.

Dismantling of version C

Unscrew the housing screws (27-3) and remove the housing (06). Unscrew the locking nut (04-2). Hold the shaft-extension (02) between the pump and the motor tight with a fork wrench and unscrew the impeller (04). All parts have right-hand thread. The impeller is best removed with the use of a ribbon gripper. All this version`s axial face sealing parts are located on the shaft extension (02) and can easily be removed from this sheath. Remove the cover (05) from the flange (01). A stationary ring (33) and a o-ring seal (34) are to be found in the cover. Push the stationary ring and the o-ring seal out off the cover.

Checking the shaft-extension (02)

The shaft-extension must not present any mechanical or chemical damage. Should the shaft-extension need replacing, remove the cotter pin (29). Then remove the shaft-extension from the motor shaft with a take-off device. When assembling the new shaft-extension, ensure compliance with all measurements and distances (see drawing).

Attention!

When ordering spare parts, please mention the pump`s reference number.

Specification A

Fit the stationary seal (33) onto the o-ring seal (34) and press both down into the cover (05).

Place the assembled cover on the flange (01). Unite the thrust collar (32-1) and the rotating seal (30) and slide over the shaft protector (03) on the rear side of the impeller. The thrust-collar must be pushed right down into the groove on the impeller.

Specification B

Fit the stationary seal (33) onto the o-ring seal (34) and press both down into the cover (05).

Place the assembled cover on the flange (01). Push the coil spring (32) over the shaft protector (03) on the rear side of the impeller. Insert the o-ring seal (31) and the thrust washer (35) into the rotating seal (30). Push all the parts together onto the shaft protector. The spring carrier must come to rest in the groove on the housing ring.

Specification C

Since this version is not equipped with a shaft protector, all the axial face sealing parts are to be mounted on the shaft extension.

Fit the stationary seal (33) onto the o-ring seal (34) and press both down into the cover (05).

Place the assembled cover on the flange (01), insert the o-ring seal (31) and the thrust washer (35) into the rotating seal (30) and push them and the coil spring over the shaft extension (02) until the rotating seal and the stationary seal come into contact.

Please ensure utmost cleanliness during assembly, especially of the slide rings`sealing surfaces.

For all versions, screw the impeller down onto the shaft extension`s bearing surfaces and lock it with the following parts:

specification A + B with locking bolt (04-1) and the cap (04-3); specification C with locking washer (42-4) and a locking nut (04-2).

Replace the housing seal (36) if necessary and then put the housing back and tighten with the housing screws.

Release the pump shaft by rotating it and check for smooth and even running.

When starting the pump up again, please comply with the instructions for **initial commissioning**.

Parts Description of the S Pump Series

Design C

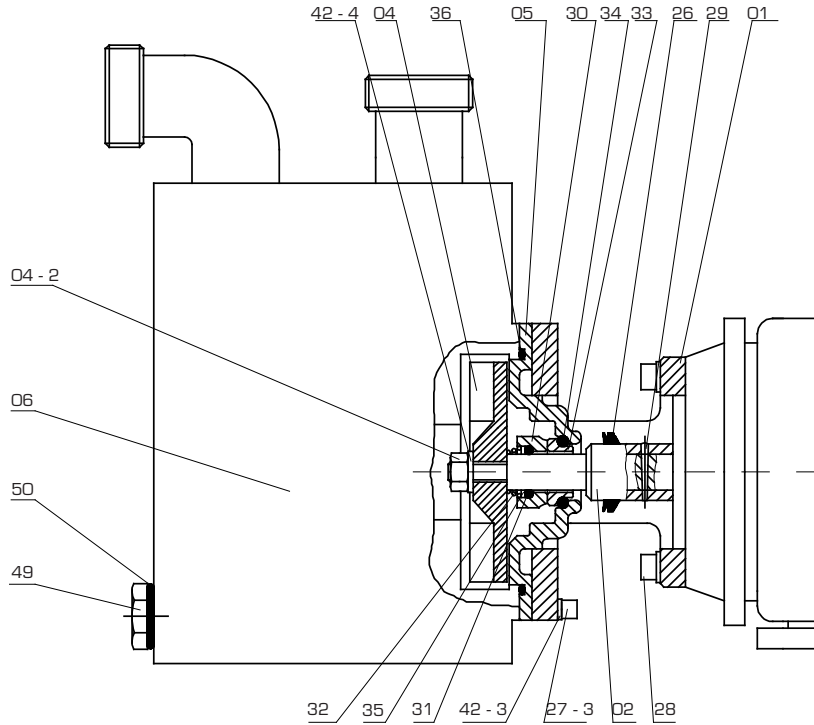

part-no.	part	material		for design
		standard	on request	
01	mounting flange	Aluminium	1.4571	A, B, C
02	shaft ext./C	1.4571	Hastelloy C	A, B, C
04	impeller/PVDF	1.4571-inset	Hastelloy C-inset	C
04 - 1	locking bolt	A4	Hastelloy C	A, B
04 - 2	locking nut	A4	Hastelloy C	C
04 - 3	cap	PVDF		A, B
04/03	impeller/PVDF	1.4571-inset	Hastelloy C-inset	A, B
05	back plate	PVDF		A, B, C
06	pump housing	PP	PVC	A, B, C
26	flinging disc	rubber		A, B, C
27 - 3	cylinder bolt	A4		A, B, C
28	cylinder bolt and washer	A4		A, B, C
29	cotter pin	1.4305		A, B, C
30	rotating seal	Carbon	SiC	A, B, C
31	o-ring seal	FKM*	FEP / EPDM	B, C
32	coil spring	Hastelloy C		B, C
32 - 1	thrust collar	FKM*		A
33	stationary seal	ceramic	SiC	A, B, C
34	o-ring seal	FKM*	FEP / EPDM	A, B, C
35	thrust washer	A4	Hastelloy C	B, C
36	housing seal	FKM*	FEP / EPDM	A, B, C
42 - 3	washer	A4		A, B, C
42 - 4	locking washer	A4	Hastelloy C	C
49	damper	PP	PVC	A, B, C
50	o-ring	FKM*	FEP / EPDM	A, B, C

*FKM = e.g. Viton®

Design A

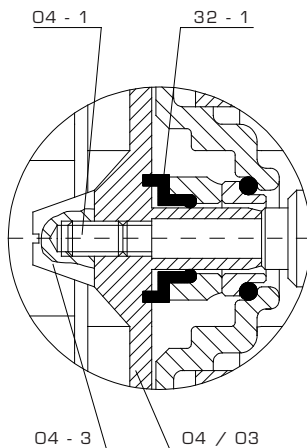

Design B

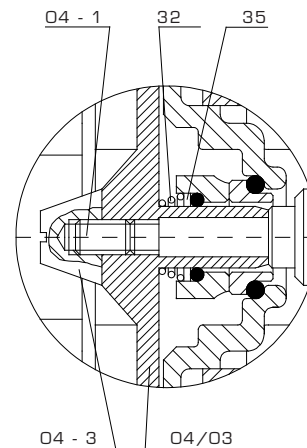

Dismantling | Assembly of the shaft extension ⁷

S Pump Series: with a single mechanical axial face seal

Remove the cotter pin (29) by punching it out.

Strip the shaft extension (02).

Unscrew the flange (01) from the motor.

Mount a new shaft extension (02).

In the event of incorporated flange, adjust assembly dimension "A".

Bore and pin the shaft extension.

Test for concentric running.

Screw the flange (01) and all other parts and mount in accordance with the repair instructions.

Dimension	A in mm
80 - 100	7,5
115	11,0
130	9,0
150 - 210	11,0

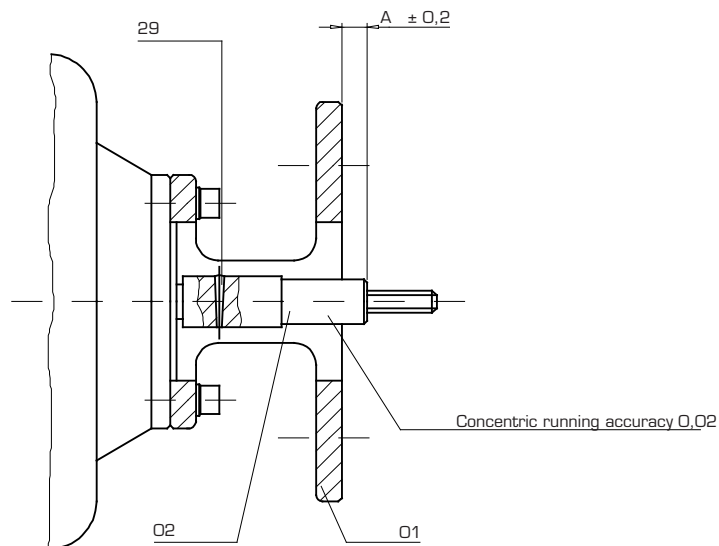

Characteristics of the S Pump Series

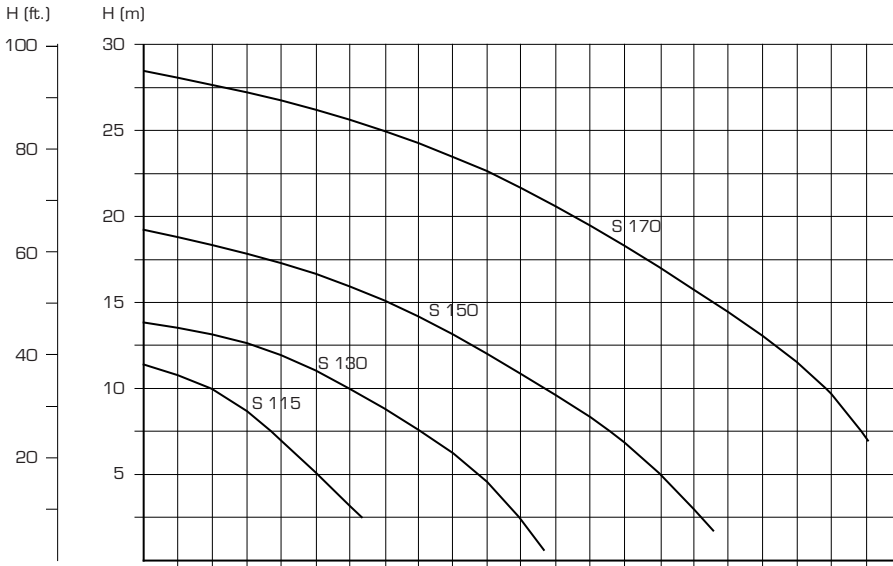

S 115 - S 170
Pump Series

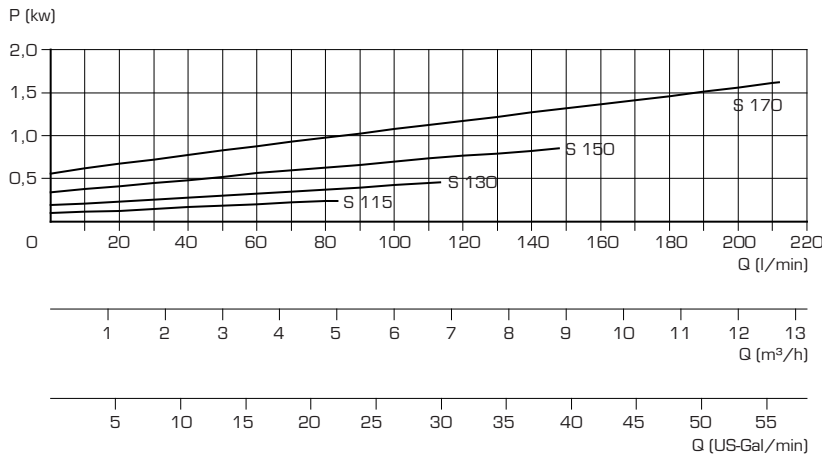

Motor power

S 170	2,20 kw
S 150	1,10 kw
S 130	0,55 kw
S 115	0,25 kw

Characteristic lines measured with water, 20° C and 2900 Rpm (50 Hz.)

Specification of the S Pump Series

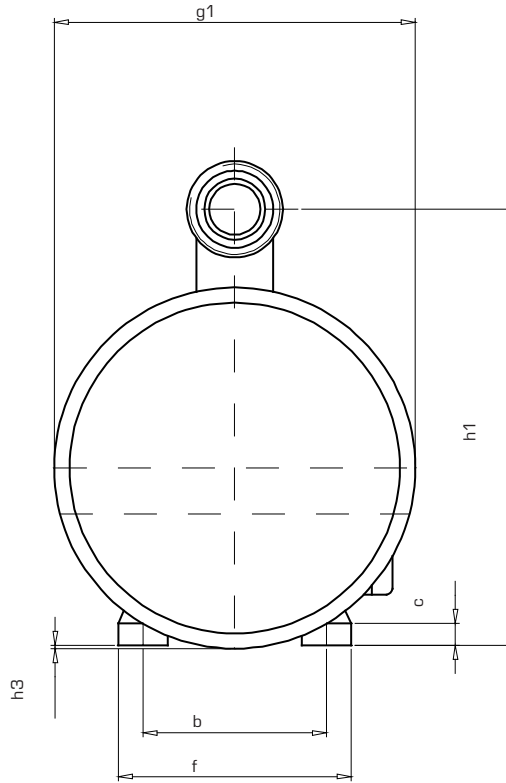

type	h	h1	h2	h3	l	l1	l2	g	g1	a	b	e	f	c	ø s	suction head m	suction/pressure connections			housing capacity l	weights kg
																	nom. bore	d	male threaded		
S 115	63	214	210	19	421	138	272	123	200	80	100	100	125	10	7	3	20	25	G1 1/4"	2,5	6,7
S 130	71	228	220	11	456	149	288	139	200	90	112	108	140	11	8	3	25	32	G1 1/2"	2,5	9,7
S 150	80	252	244	12	502	172	317	154	225	100	125	125	160	11	10	4	25	32	G1 1/2"	3,0	16,1
S 170	90	282	271	15	583	196	364	177	250	125	140	152	180	14	11	5	32	40	G 2"	5,0	23,7

The dimensions of the motors refer to three-phase standard motors.

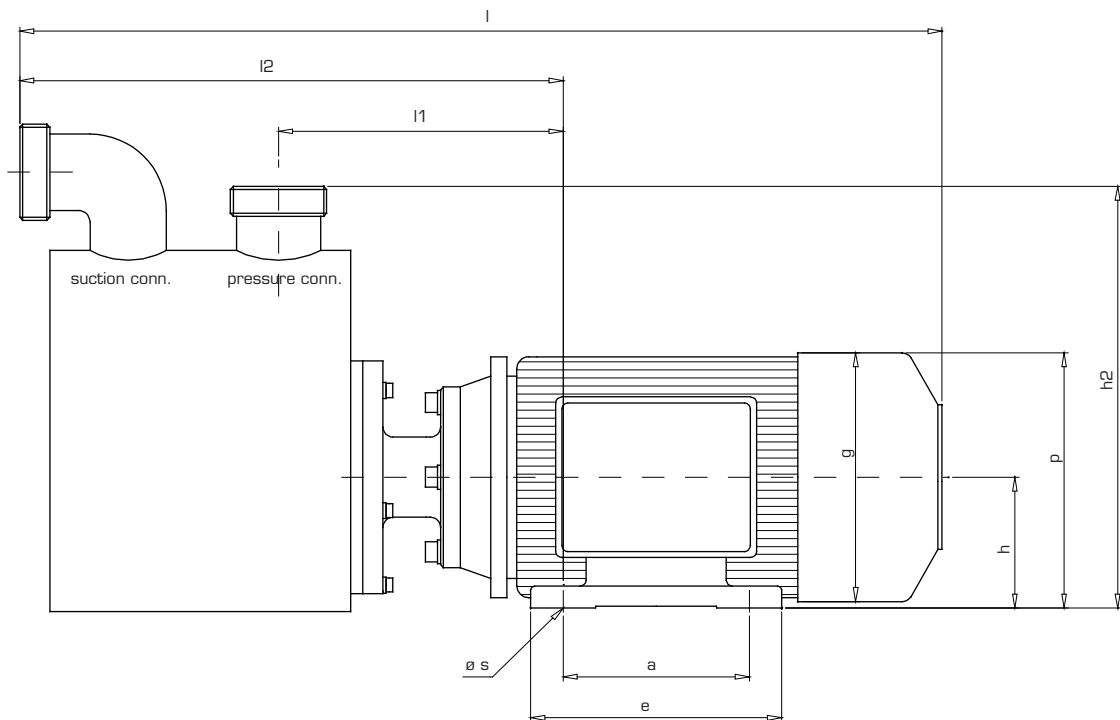

General conditions

SCHMITT centrifugal pumps meet very high design and engineering specifications.

Appropriate assembly and operation, as recommended in the present operating instructions, are a prerequisite for troublefree continuous operation.

Thus, in order necessary to comply with the present instructions for assembly and commissioning of the pumps, as well as for maintenance work, it is necessary to read these carefully and to comply with the recommendations. Each and every **SCHMITT centrifugal pump** has been given a reference number which is to be mentioned in all subsequent correspondence and when ordering spare parts.

Warranty

We provide a guarantee in accordance with our General Terms of Sale.

Please advise us immediately of any damage which may have occurred during the guarantee period. Only prompt action will give you a right to claim on the guarantee.

We shall only be liable for all those materials and versions recommended by us, to the extent that the operating instructions and the feeding liquids match the specifications requested at the time of ordering the equipment.

Please contact us should any alterations have to be made concerning the concentrations and the temperature of the feeding medium or the hydraulic data. We shall then check to see whether the pump supplied by us can be used in such operating conditions. As mentioned in our General Terms of Delivery, we shall not be liable for any damage resulting from non-compliance with the operating instructions.

Please inform us writing prior to any modifications or maintenance work carried out during the period of guarantee. Omission to do so will cancel the present guarantee. Such modifications or maintenance work are only to be carried out by specialised personnel or else you may send us the pump for an expert opinion or repairs.

We shall not to be held liable for any pump parts which show signs of premature wear and tear due to their material properties or the way in which they were used, such as axial face seals, seals and similar.

We only guarantee spare parts not made by us within the limits of the guarantee awarded to us by the sub-contractor.