



SCHMITT
Kreispumpen

**chemical resistant pumps
for corrosive and highly pure media**

Operating Maintenance Assembly Instruction



T Pump Series

submersible pumps

materials: PP or PVDF

General instructions

The present operating instructions must be complied with when installing, operating and servicing the pumps. This is the reason why these instructions must be read by the operator, the assembling personnel and all the other specialists/operators before installing and commissioning the pump. These instructions must be readily available for consultation at the site of installation.

The personnel in charge of operation, maintenance, inspection and assembly must be qualified to carry out this work. The scope of the personnel's responsibility, competence and supervision must be precisely defined by the management. The management must also ensure that the operating instructions are fully understood and complied with by the personnel.

Non-compliance with the present instructions may not only cause damage to the environment and be dangerous for the personnel but may also result in the total destruction of or damage to the pump or the installation.

The present instructions, current national measures for accident prevention, and all internal works-, operating- and safety instructions specified by the user are to be complied with.

The work is to be carried out on inactive pumps. Pumps which are used with hazardous materials must be decontaminated. Before started such pumps up again, the instructions for initial commissioning are to be complied with.

Installing the pump

Before installing the pump on a container or pump well, please comply with the instructions concerning the assembly opening. Install the pump at the chosen site and screw into vertical position with the appropriate screws. There are four boreholes on the flange of all pumps.

Relocating pipelines

Prior to installing a **SCHMITT centrifugal pump**, please ensure the very best and appropriate arrangement of the connecting tubes. Inappropriate tube cross section and erroneous arrangement can result in lost performance, and even damage.

The pipeline's nominal width and the incorporated armature must be of equal width or wider than the pump's nominal width. Pipelines are to be connected to the pump in such a manner that no forces act on the pump (e.g. mismatch, weight or dilation when hot liquids are being pumped). Use compensators or flexible connection pieces. This also applies in the event of metal pipelines.

Operation

Avoid pumping solids and mud.

Pump Series: T 100 - T 190
Pump material: PP or PVDF

The immersion pumps, belonging to thi series, are perfectly **safe to run dry** and are only suitable for vertical installation.

The pumps are rested on and attached to the flange below the driving motor.

Please ensure that the pumps are fitted to a stable surface.

Install the pumps at the chosen site and connect the pressure line according to instructions.

Also ensure that all the connected lines are absolutely watertight.

Before connecting the motor to the power supply, please match the voltage with the indications on the motor.; check explosion-proof motors for their protection class.

The connection must comply with VDE regulations and those of the local electricity board.

Test the pump`s rotational direction by giving it a brief current pulse. Switch the pump on by activating the closed slide valve on its pressure side. Subsequently, open the slide valve to reach the desired flowing or working point.

Do not operate the pump against the closed, pressure-side slide valve.

Only use the pumps for the pumping mediums and operating conditions specified in the order form. As stated in our General Terms of Sale, we shall not be held liable, for any damage which resulted from non-compliance with the present operating instructions.

Pump Series: T 100 - T 190
Pump material: PP or PVDF

Before dismantling the pumps, secure them so as to ensure that they cannot be switched on. The pump housing must have reached ambient temperature, must be unpressurized and empty.

Carefully clean the pump when this is used for hazardous and environmentally dangerous feeding media. Pollutants from this operation are to be disposed of in the appropriate manner.

Dismantling

Release the hexagon bolt (27) to remove the housing (06) and unscrew the cap (04-3) (right-hand thread).

Remove the impeller (04/03) from the shaft (02). The impeller and the shaft are fitted with an featherkey.

First undo the cheese head screws (27-3) to remove the pump support (05).

The shaft (02) is mounted on the motor shaft and attached with a cotter pin (29).

Check the shaft for damage and test for concentric running (maximum permissible discrepancy: 0.02mm).

Check all parts for damage and replace faulty parts with original spare parts.

Attention!

When ordering spare parts, please mention the pump`s reference number.

Assembling

Assembly is facilitated when the motor is installed vertically on the ventilator cap.

Place the pump support (05) over the shaft on the motor flange, tighten the cheese head screws (27-3), push the impeller (04/03) over the motor shaft, tighten the cap (04-3).

Check for smooth and even running by rotating the motor fan blade or the impeller. Insert the housing seal (36), tighten the housing (06) with the corresponding hexagon bolt (27).

When starting the pump up again, please comply with the instructions for **initial commissioning**.

Shaft installation instructions for submersible pumps

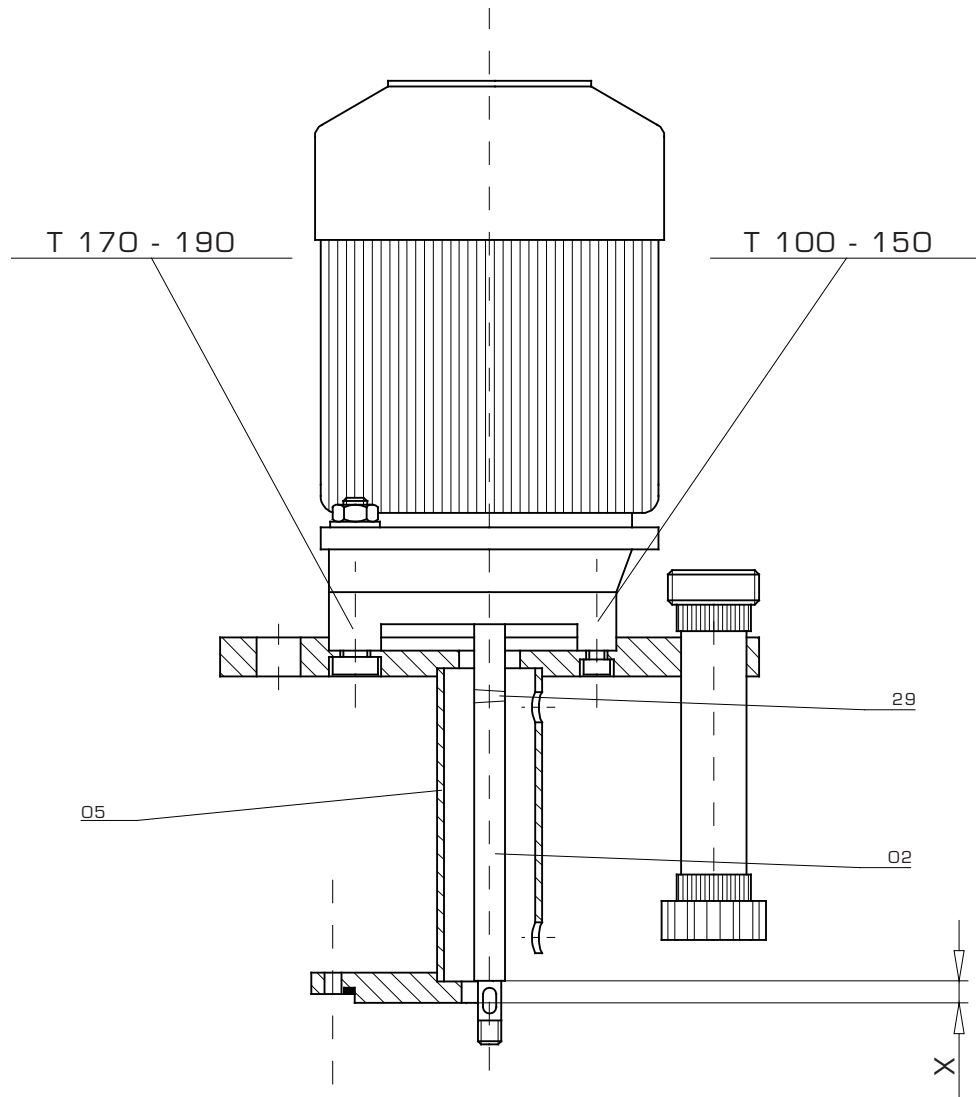

Place the pump support (05) over the shaft on the motor flange, insert the shaft (02) and press it over the motor shaft till you reach the measure X as specified.

Remove the pump support (05) again, drill the shaft (02) in the region of the motor shaft and attach it with a cotter pin (29).

Check the shaft for damage and test for concentric running (maximum permissible discrepancy: 0.02m).

Type	measure X
T 100	6 mm
T 115	7 mm
T 130	6 mm
T 150	7 mm
T 170	11 mm
T 190	12,5 mm

Parts Description of the T Pump series

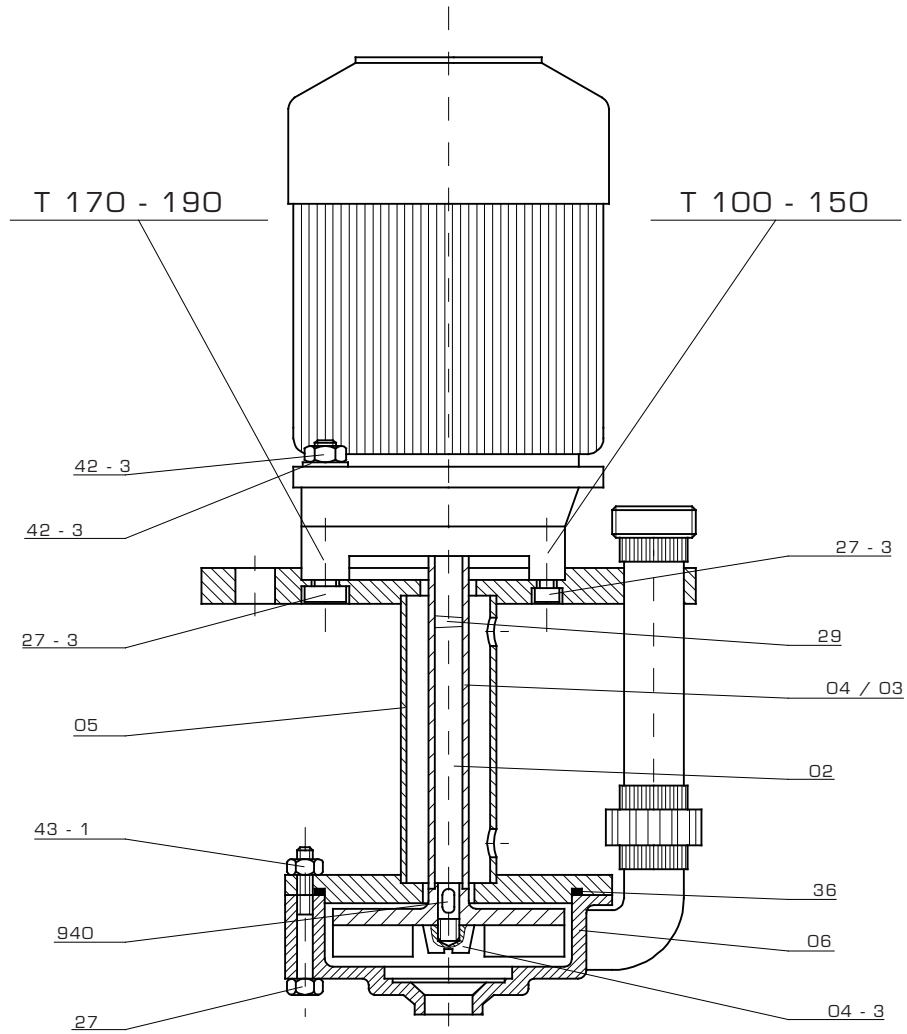

part-no.	part	material	
		standard	on request
02	shaft	Stahl	
04/03	impeller with shaft coating	PP	PVDF
04 - 3	cap	PVDF	
05	support tube	PP	PVDF
06	pump housing	PP	PVDF
27	hexagon bolt	PP*	PVDF
27 - 3	bolt	A4	
29	cotter pin	1.4305	
36	pump housing seal	FKM**	EPDM - FEP
42-3	washer	A4	
43	hexagon bolt	A4	
43 - 1	hexagon bolt	PP*	PVDF
940	feather key	1.4305	

*for T 100 - 130: PVDF

**FKM = e.g. Viton®

Characteristics of the T Pump Series

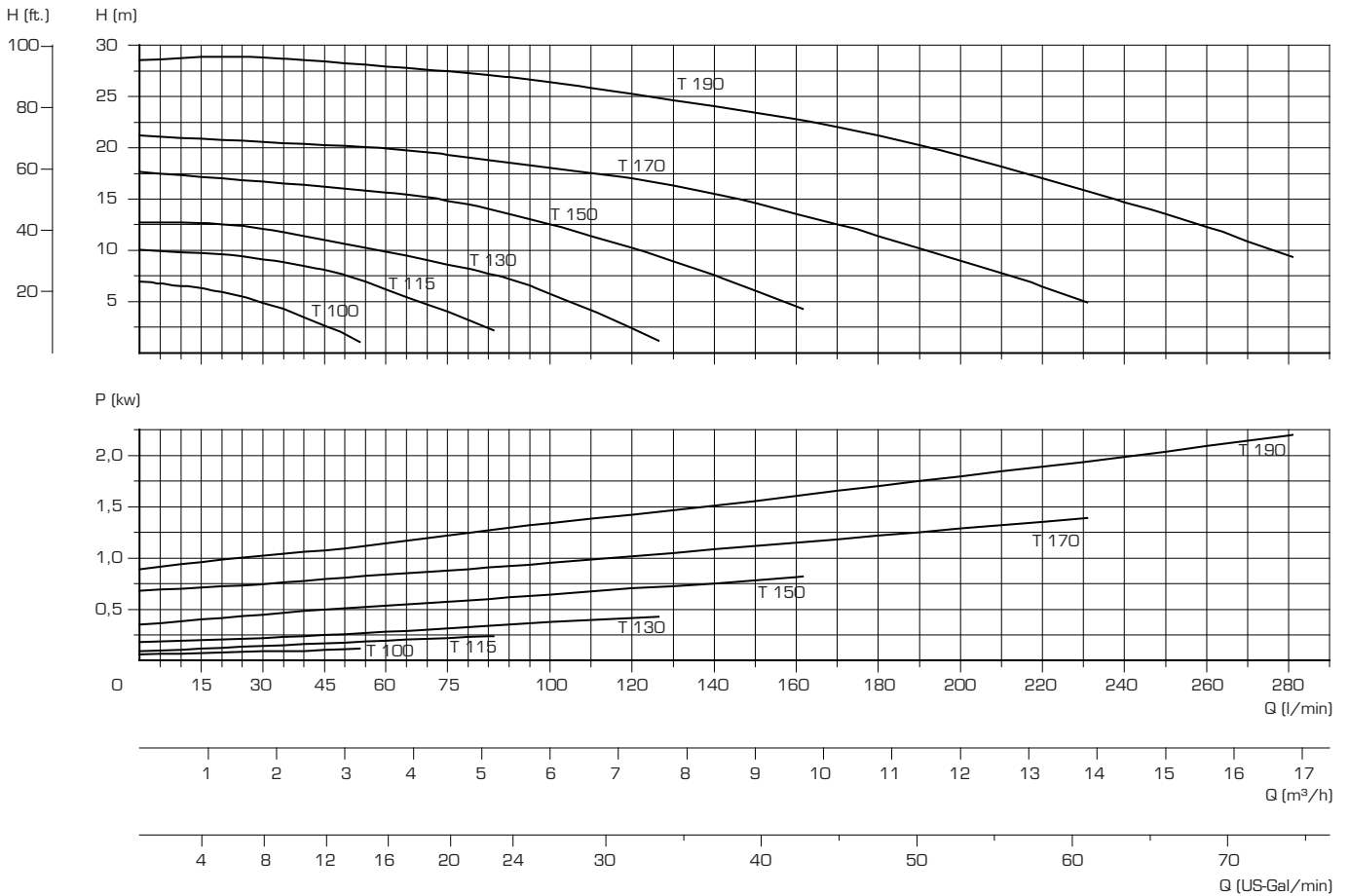

Characteristic lines measured with water, 20° C and 2900 Rpm (50 Hz.)

type	motor power P	ET = depth of immersion
	kW	mm
T 100	0,12	200
T 115	0,25	200 - 300 - 400
T 130	0,55	200 - 300 - 400
T 150	0,75	300 - 400 - 500
T 170	1,50	400 - 600 - 800
T 190	2,20	400 - 600 - 800

Specification of the T Pump Series

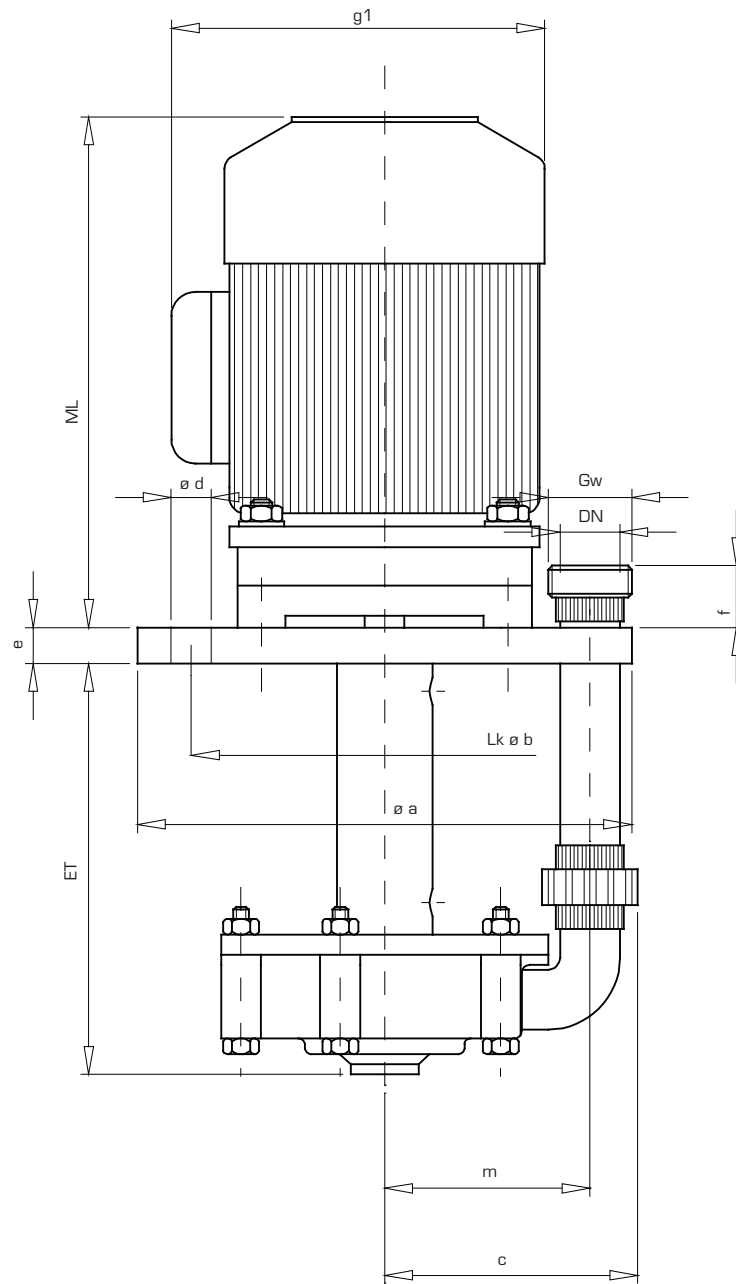

type	ø a	ø b	c	ø d*	e	f	g1	m	ML	Gw	DN
T 100	220	150	119	11	18	30	147	90	191	G 1"	15
T 115	230	170	126	11	18	30	158	90	211	G 1 ¼"	20
T 130	240	200	129	11	18	30	182	100	241	G 1 ¼"	20
T 150	265	225	142	11	22	30	209	113	263	G 1 ¼"	20
T 170	320	280	162	13	22	55	235	130	278	G 1 ½"	25
T 190	330	280	173	13	22	55	235	141	303	G 1 ½"	25

The dimensions of the motors refer to three-phase standard motors.

General conditions

SCHMITT centrifugal pumps meet very high design and engineering specifications.

Appropriate assembly and operation, as recommended in the present operating instructions, are a prerequisite for troublefree continuous operation.

Thus, in order necessary to comply with the present instructions for assembly and commissioning of the pumps, as well as for maintenance work, it is necessary to read these carefully and to comply with the recommendations. Each and every **SCHMITT centrifugal pump** has been given a reference number which is to be mentioned in all subsequent correspondence and when ordering spare parts.

Warranty

We provide a guarantee in accordance with our General Terms of Sale.

Please advise us immediately of any damage which may have occurred during the guarantee period. Only prompt action will give you a right to claim on the guarantee.

We shall only be liable for all those materials and versions recommended by us, to the extent that the operating instructions and the feeding liquids match the specifications requested at the time of ordering the equipment.

Please contact us should any alterations have to be made concerning the concentrations and the temperature of the feeding medium or the hydraulic data. We shall then check to see whether the pump supplied by us can be used in such operating conditions. As mentioned in our General Terms of Delivery, we shall not be liable for any damage resulting from non-compliance with the operating instructions.

Please inform us writing prior to any modifications or maintenance work carried out during the period of guarantee. Omission to do so will cancel the present guarantee. Such modifications or maintenance work are only to be carried out by specialised personnel or else you may send us the pump for an expert opinion or repairs.

We shall not to be held liable for any pump parts which show signs of premature wear and tear due to their material properties or the way in which they were used, such as axial face seals, seals and similar.

We only guarantee spare parts not made by us within the limits of the guarantee awarded to us by the sub-contractor.