

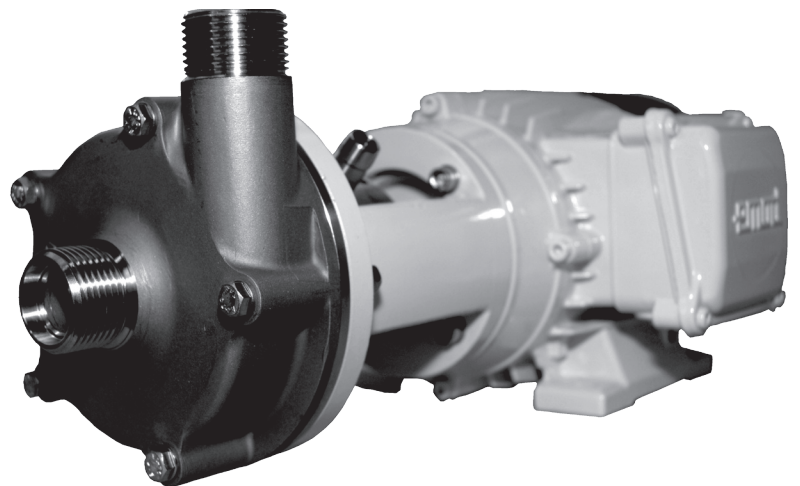

SCHMITT
Kreispumpen

**chemical resistant pumps
for corrosive and highly pure media**

Operating Maintenance Assembly Instruction



UP - DO Pump Series

**normal priming,
centrifugal pumps
with a double mechanical seal**

materials: stainless steel 1.4581

General instructions

The present operating instructions must be complied with when installing, operating and servicing the pumps. This is the reason why these instructions must be read by the operator, the assembling personnel and all the other specialists/operators before installing and commissioning the pump. These instructions must be readily available for consultation at the site of installation.

The personnel in charge of operation, maintenance, inspection and assembly must be qualified to carry out this work. The scope of the personnel's responsibility, competence and supervision must be precisely defined by the management. The management must also ensure that the operating instructions are fully understood and complied with by the personnel.

Non-compliance with the present instructions may not only cause damage to the environment and be dangerous for the personnel but may also result in the total destruction of or damage to the pump or the installation.

The present instructions, current national measures for accident prevention, and all internal works-, operating- and safety instructions specified by the user are to be complied with.

The work is to be carried out on inactive pumps. Pumps which are used with hazardous materials must be decontaminated. Before started such pumps up again, the instructions for initial commissioning are to be complied with.

Installing the pump

The pump is to be installed horizontally at the chosen operating site. Monobloc pumps are installed stress-free in situ (on the ground or the bottom plate) with the help of the feet.

Relocating pipelines

Prior to installing a **SCHMITT centrifugal pump**, please ensure the very best and appropriate arrangement of the connecting tubes. Inappropriate tube cross section and erroneous arrangement can result in lost performance, and even damage.

The pipeline's nominal width and the incorporated armature must be of equal width or wider than the pump's nominal width. Suction lines must be as short as possible. Sharp bends must be avoided, especially before the pump's suction connection pieces. Pipelines are to be connected to the pump in such a manner that no forces act on the pump (e.g. mismatch, weight or dilation when hot liquids are being pumped). Use compensators or flexible connection pieces. This also applies in the event of metal pipelines.

Operation

Avoid pumping solids and mud. If necessary, overflow protection, filters or screen cages are to be incorporated into the suction line. Please be careful that these do not become blocked since the pump will otherwise cavitate. This can result in damage, particularly to the axial face seals.

Pump Series: UP - DO 80 to UP - DO 210
Materials: Stainless Steel 1.4581

These pumps are “normal priming”, i.e. the feeding medium has to feed into the pump.

The axial input is located centrally in the housing, with the output leading tangentially right to the top (standard version).

These pumps are fitted with a mechanical, internal, double-acting axial face seal which is charged by a sealing liquid compatible to the feeding medium. The axial face seals are made of various different materials, depending on their use.

Once the pumps have been installed at the chosen site, and the suction and pressure lines have been properly connected, the pump is filled with liquid. Please make sure that the lines and the pump have been bled. Also ensure that all the connected lines are absolutely watertight.

Before connecting the motor to the power supply, please match the voltage with the indications on the motor.; check explosion-proof motors for their protection class.

The connection must comply with VDE regulations and those of the local electricity board.

Attention!

Prior to the rotational direction test of the motor, please ensure the pump is filled with sealing liquid.

Test the pump's rotational direction by giving it a brief current pulse. Switch the pump on by activating the closed slide valve on its pressure side. Subsequently, open the slide valve to reach the desired flowing or working point.

Suction-side throttling is not permitted. This results in cavitation; performance levels fall off and damage may be caused to pump parts and axial face seals.

Only use the pumps for the pumping mediums and operating conditions specified in the order form. As stated in our General Terms of Sale, we shall not be held liable, for any damage which resulted from non-compliance with the present operating instructions.

Water supply connection diagram

for double-acting axial face seal pumps

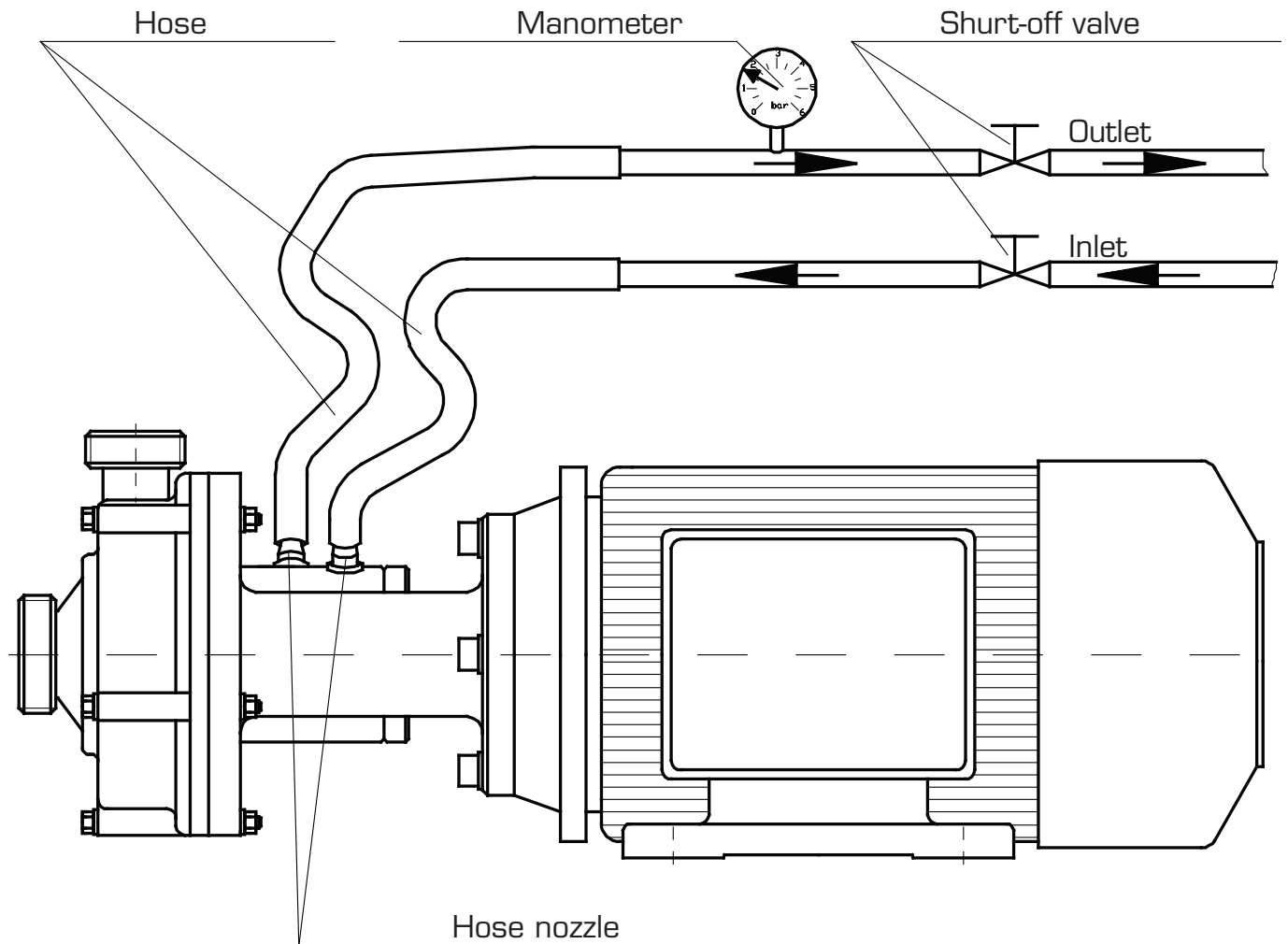

The necessary sealing pressure can be determined as follows:

$$P_{\text{seal}} \text{ (bar)} = H/20 \times p + 1 \text{ to } 1,5 \text{ bar}$$

p (kg/dm³) = Density of feeding liquid

H = Delivery head

Pump Series: UP - DO 80 to UP - DO 210

Before dismantling the pumps, secure them so as to ensure that they cannot be switched on. The pump housing must have reached ambient temperature, must be unpressurized and empty. Carefully clean the pump when this is used for hazardous and environmentally dangerous feeding media. Pollutants from this operation are to be disposed of in the appropriate manner.

Dismantling of version C

Release locking nut (04-2) and remove locking washer (42-4).

Continue as for version B.

This version is not fitted with a shaft protector (03).

Assembling specification B and C

Place the stationary seal (33), the o-ring seal (34) and the O-ring (5-2) on the insert (05-1) and push over the shaft extension (02) until the motor is reached.

Fit the rotating seal (30) on the atmospheric pressure-side of the pump with the o-ring seal (31) and push them and the distance ring (39) onto the shaft. Insert the right-hand threaded coil spring by ensuring that the opened up end of the spring rests on the distance ring's carrier pin. Insert the securing ring (37) into its groove.

Additional assembly instructions for specification C:

Push the left-hand-thread coil spring right up to the securing ring on the shaft extension (02). Push both the product-side rotating seal ring (30) and the o-ring seal (31) and the thrust washer (35) over the shaft extension, right up to the spring. Please ensure that the end of the spring comes to rest in the notch on the housing slide ring.

Assembling specification B and C

Fit the stationary seal (33) onto the o-ring seal (34) and insert into the cover (05), subsequently resting it on the flange (01); insert the screw into the flange and tighten. Screw the insert (05-1) into the cover and then remove the locking screw from the flange. Screw the impeller (04) back tight onto the shaft extension, while holding the shaft tight between the pump and motor. Insert and tighten the locking nut and cap (version B) or the locking washer and locking nut (version C). Put the housing seal (36) back in place, replace the housing and tighten with the housing screws. Screw the sealing circuit's hose nozzle (40) back into the cover.

When starting the pump up again, please comply with the instructions for **initial commissioning**.

Attention!

When ordering spare parts, please mention the pump's reference number!

Parts Description of the UP - DO Pump series ⁶

Design C

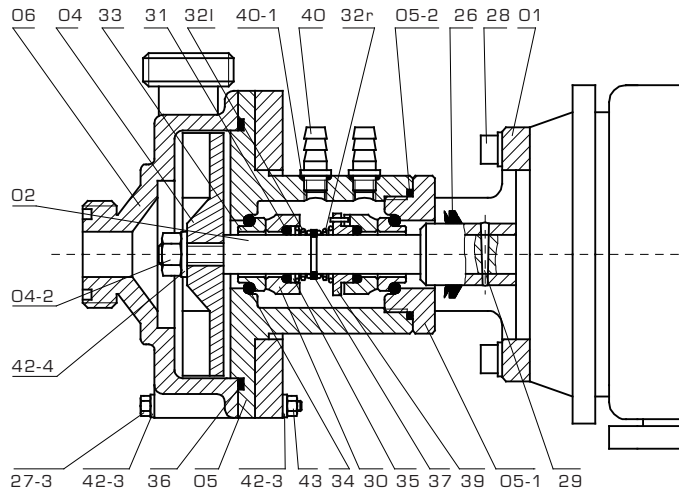

part-no.	part	materials	
		standard	on request
01	mounting flange	Aluminium	
02	shaft extension	1.4571	
04	impeller	1.4581	
04 - 2	locking nut	1.4571	
05	backplate	1.4571	
05 - 1	inset	1.4571	
05 - 2	O -Ring	Viton	
06	pump housing	1.4581	
26	flinging disc	rubber	
27 - 3	hexagon bolt	A4	
28	bolt + washer	A4	
29	cotter pin	1.4305	
30	rotating seal	carbon	SiC
31	o-ring seal	Viton	FEP or EPDM
32	coil spring	Hastelloy C	
33	stationary seal	ceramic	SiC
34	o-ring seal	Viton	FEP or EPDM
35	thrust washer	1.4571	
36	pump housing seal	Viton	FEP or EPDM
37	lockwasher	A4	
39	spacer ring	1.4305	
40	hose nozzle	1.4305	
40 - 1	O -Ring	Viton	
42 - 3	washer	A4	
42 - 4	locking washer	A4	
43	hexagon nut	A4	

Dismantling | Assembly of the shaft extension ⁷

U - DO Pump Series:
with a double mechanical axial face seal

Remove the cotter pin (29) by punching it out.

Strip the shaft extension (02).

Unscrew the flange (01) from the motor.

Mount a new shaft extension (02).

In the event of incorporated flange, adjust assembly dimension "A".

Bore and pin the shaft extension.

Test for concentric running.

Screw the flange (01) and all other parts and mount in accordance with the repair instructions.

Dimension	A in mm
80 - 100	7,5
115	11,0
130	9,0
150 - 210	11,0

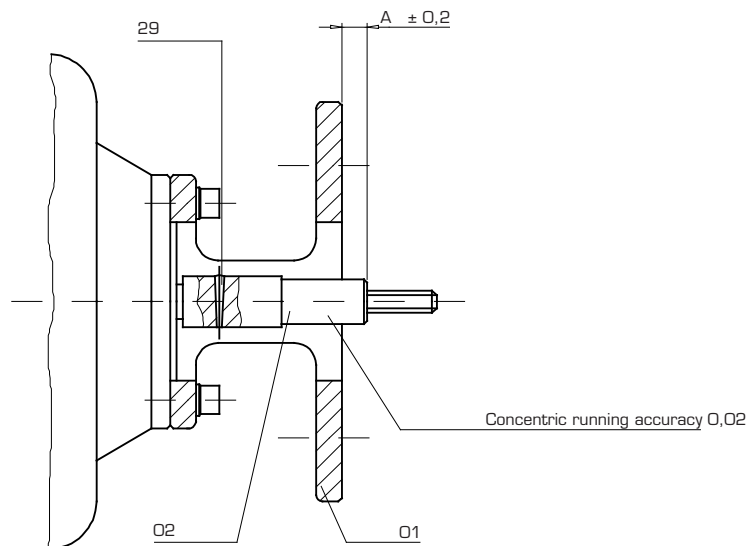

Specification of the UP - DO Pump Series

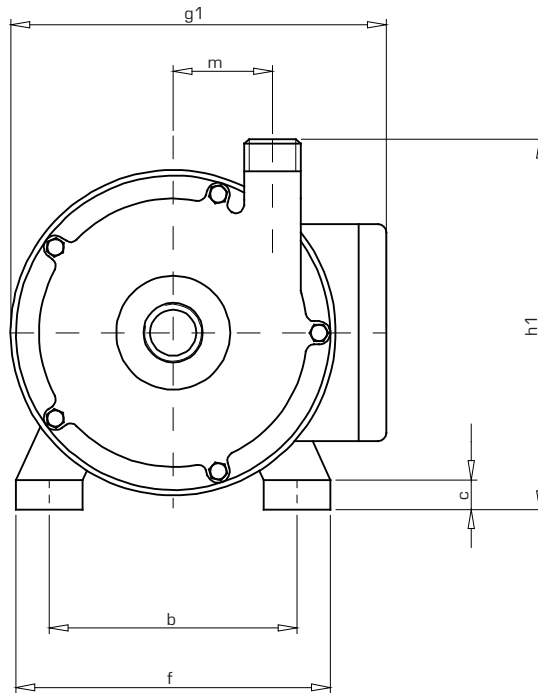

type	h	p	g	a	e	ø s	b	f	c	g1	ø z	l	l1	l2	m	h1	suction conn.		pressure conn.		weights kg
																	nom. bore	male thread	nom. bore	male thread	
U-DO 100	56	112	111	71	90	6	90	110	9	146	13	321	146	187	35	126	15	G3/4"	15	G3/4"	6,7
U-DO 115	63	125	123	80	100	7	100	125	10	158	13	367	171	216	35	140	15	G3/4"	15	G3/4"	8,0
U-DO 130	71	140	139	90	108	8	112	140	11	182	13	393	177	222	42	157	20	G1"	20	G1"	13,0
U-DO 150	80	157	154	100	125	10	125	160	11	187	13	436	200	251	47	176	25	G1 1/4"	20	G1"	18,7
U-DO 170	90	180	177	125	152	11	140	180	14	240	13	520	242	301	55	200	32	G1 1/2"	25	G1 1/4"	28,0
U-DO 190	100	197	194	140	170	12	160	200	15	258	13	548	249	308	60	220	32	G1 1/2"	25	G1 1/4"	39,0
U-DO 210	112	260	224	140	180	12	190	235	16	296	13	575	256	320	70	242	40	G2"	32	G1 1/2"	61,0

The dimensions of the motors refer to three-phase standard motors.

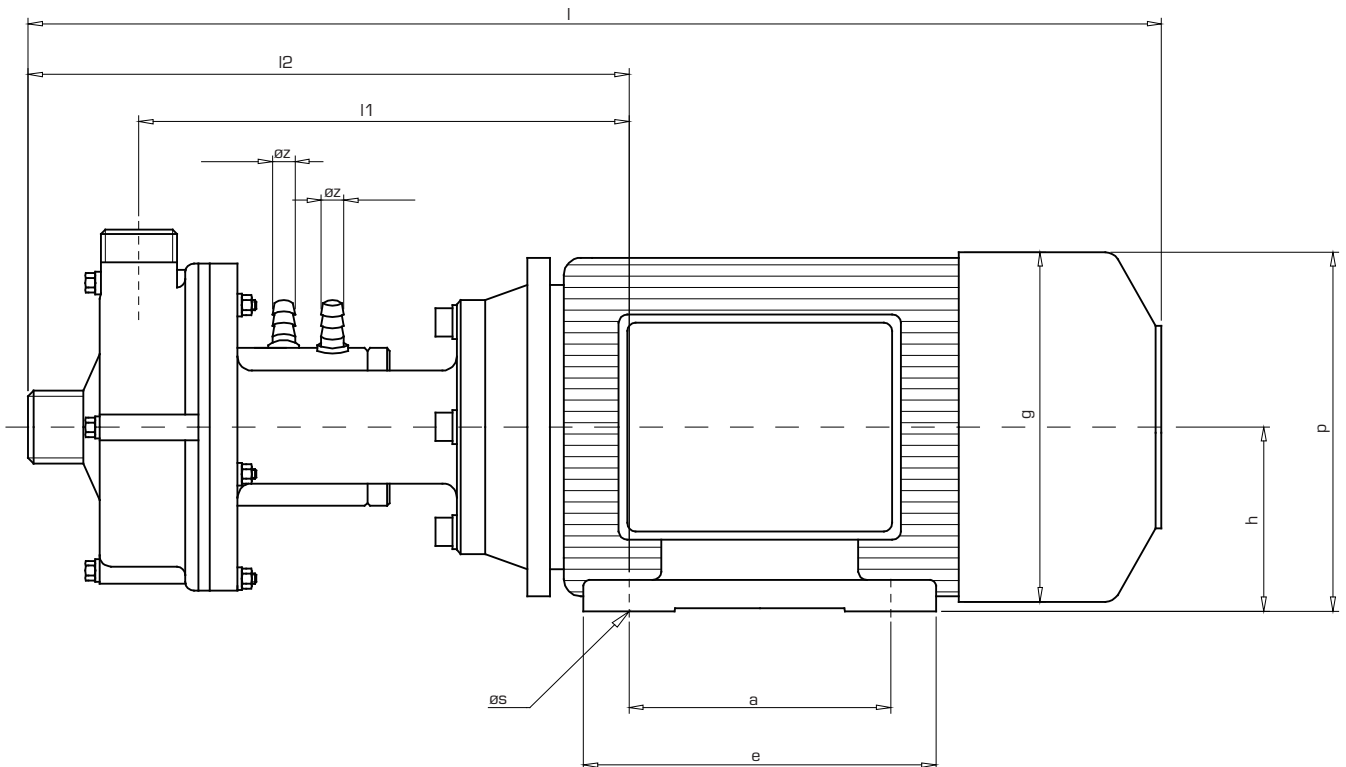

General conditions

SCHMITT centrifugal pumps meet very high design and engineering specifications.

Appropriate assembly and operation, as recommended in the present operating instructions, are a prerequisite for troublefree continuous operation.

Thus, in order necessary to comply with the present instructions for assembly and commissioning of the pumps, as well as for maintenance work, it is necessary to read these carefully and to comply with the recommendations. Each and every **SCHMITT centrifugal pump** has been given a reference number which is to be mentioned in all subsequent correspondence and when ordering spare parts.

Warranty

We provide a guarantee in accordance with our General Terms of Sale.

Please advise us immediately of any damage which may have occurred during the guarantee period. Only prompt action will give you a right to claim on the guarantee.

We shall only be liable for all those materials and versions recommended by us, to the extent that the operating instructions and the feeding liquids match the specifications requested at the time of ordering the equipment.

Please contact us should any alterations have to be made concerning the concentrations and the temperature of the feeding medium or the hydraulic data. We shall then check to see whether the pump supplied by us can be used in such operating conditions. As mentioned in our General Terms of Delivery, we shall not be liable for any damage resulting from non-compliance with the operating instructions.

Please inform us writing prior to any modifications or maintenance work carried out during the period of guarantee. Omission to do so will cancel the present guarantee. Such modifications or maintenance work are only to be carried out by specialised personnel or else you may send us the pump for an expert opinion or repairs.

We shall not to be held liable for any pump parts which show signs of premature wear and tear due to their material properties or the way in which they were used, such as axial face seals, seals and similar.

We only guarantee spare parts not made by us within the limits of the guarantee awarded to us by the sub-contractor.