

SCHMITT
Kreispumpen

**chemical resistant pumps
for corrosive and highly pure media**

Operating Maintenance Assembly Instruction



TE Pump Series

submersible pumps

materials: stainless steel 1.4571

General instructions

The present operating instructions must be complied with when installing, operating and servicing the pumps. This is the reason why these instructions must be read by the operator, the assembling personnel and all the other specialists/operators before installing and commissioning the pump. These instructions must be readily available for consultation at the site of installation.

The personnel in charge of operation, maintenance, inspection and assembly must be qualified to carry out this work. The scope of the personnel's responsibility, competence and supervision must be precisely defined by the management. The management must also ensure that the operating instructions are fully understood and complied with by the personnel.

Non-compliance with the present instructions may not only cause damage to the environment and be dangerous for the personnel but may also result in the total destruction of or damage to the pump or the installation.

The present instructions, current national measures for accident prevention, and all internal works-, operating- and safety instructions specified by the user are to be complied with.

The work is to be carried out on inactive pumps. Pumps which are used with hazardous materials must be decontaminated. Before started such pumps up again, the instructions for initial commissioning are to be complied with.

Installing the pump

Before installing the pump on a container or pump well, please comply with the instructions concerning the assembly opening. Install the pump at the chosen site and screw into vertical position with the appropriate screws. There are four boreholes on the flange of all pumps.

Relocating pipelines

Prior to installing a **SCHMITT centrifugal pump**, please ensure the very best and appropriate arrangement of the connecting tubes. Inappropriate tube cross section and erroneous arrangement can result in lost performance, and even damage.

The pipeline's nominal width and the incorporated armature must be of equal width or wider than the pump's nominal width. Pipelines are to be connected to the pump in such a manner that no forces act on the pump (e.g. mismatch, weight or dilation when hot liquids are being pumped). Use compensators or flexible connection pieces. This also applies in the event of metal pipelines.

Operation

Avoid pumping solids and mud.

Series: TE, Sizes 115 - 190
Materials: Stainless steel 1.4571

The submersible pumps of this series are absolutely **dry run safe** and have been exclusively designed for vertical installation.

The pumps are supported and attached through the flange underneath the drive motor, which has 4 bore holes.

Care must be taken that the pumps are attached to a sturdy base.

Move the pump to its designated position and connect the pressure pipe correctly. Pumps of this series are delivered with welded screw connections (tapered seal) as standard. Care must be taken that the connected pipes are absolutely airtight.

Before the motor is connected to the local power supply, voltage must be checked against the motor's type plate, motors with explosion protection must be checked for protection class.

The connection must comply with the requirements of VDE and the local electricity supply companies.

Check the direction of rotation indicated by an arrow on the pump by applying a brief current pulse. The pump must be switched on against the closed slide on the pressure side. Then open the slide as far as necessary until the required quantity or operating point has been reached.

Only operate the pump briefly against a slide closed on the pressure side.

Pumps may only be used for the media and operating conditions specified in the order. In the event of any damage caused by non-observance of this, we cannot accept any liability, as set out in our Terms of Delivery.

Series: TE, Sizes 115 - 190
Materials: Stainless steel 1.4571

Before dismantling work starts, the pump has to be secured in such a way that it cannot be switched on. The pump housing must have cooled to the ambient temperature, be depressurised and empty.

If the pump has been operated with media that are hazardous to health and the environment, it must be cleaned carefully. The resulting pollutants must be disposed of correctly.

Dismantling

Remove the pump housing (06) by loosening the base bolts (27), screw the counternut (04-2) off (right-hand thread).

The impeller has a wedge groove and is only inserted on the shaft.

To remove the complete support tube (05), loosen the cylinder bolts (27-3) first.

The shaft (02) is inserted onto the motor shaft and fixed in place by the cotter pin (29).

Check the shaft for damage and concentricity (permissible deviation max. 0.02 mm).

Faulty shafts should only be replaced in our factory.

If parts are replaced, only use original spare parts.

Attention!

When ordering spare parts, please mention the pump`s reference number.

Assembling

The motor already has the shaft (02) fitted, fixed in place and balanced. Assembly of the other pump parts is easier when the motor is set up vertically on the fan hood.

Insert the support tube (05) over the shaft onto the motor flange, tighten the cylinder bolts (27-3), push the impeller (04) over the wedged groove, lock in place using the counternut (04-2).

Check smooth and even running by turning the impeller.

Insert the pump housing seal (36), fix the pump housing (06) in place using the base bolts (27) and the nuts (43-1).

When starting to use the pump again, follow the instructions valid for **initial operation**.

Shaft installation instructions for submersible pumps

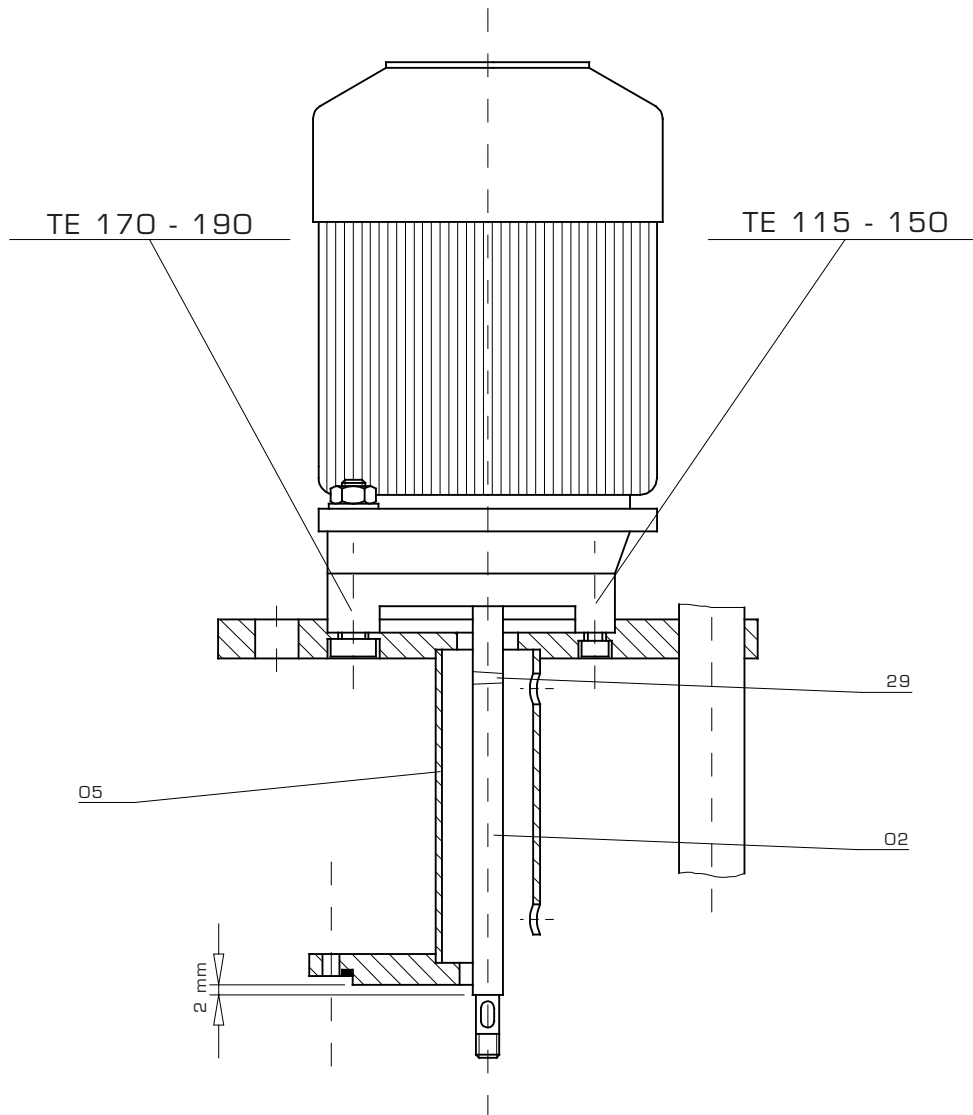

Set the support tube part 05 onto the motor, insert the shaft part 02 and press it onto the motor shaft until the given gap of 2 mm has been reached.

Remove the support tube again and drill a hole in the shaft part 02 near the motor shaft and fix in place using the cotter pin part 29.
Then check the shaft for concentricity and align if necessary.
Concentricity precision at end of shaft 0.02 mm.

Parts description for the TE series

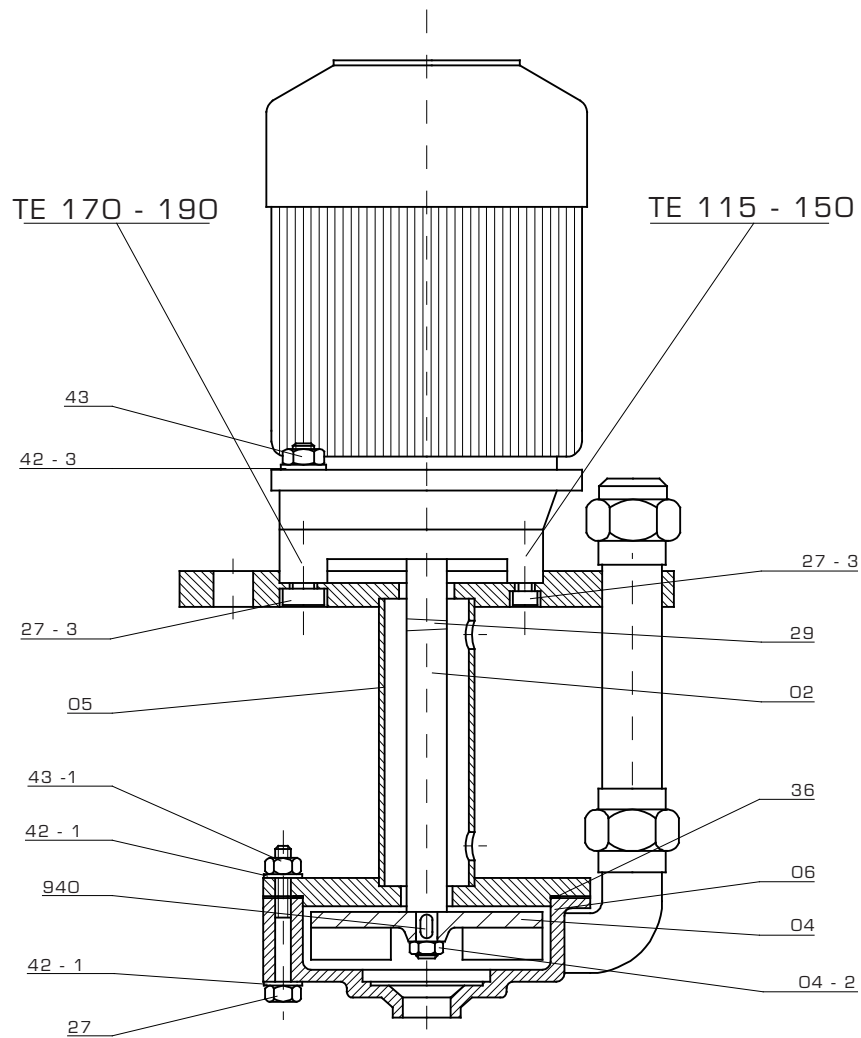

Part no.	Description	Materials
02	Shaft	1.4571
04	Impeller	1.4581
04 - 2	Counternut	A4
05	Support tube, complete	1.4571
06	Pump housing	1.4581
27	Base bolt	A4
27 - 3	Cylinder bolt	A4
29	Cotter pin	A4
36	Pump housing seal, flat	PTFE
42 - 1	Washer	A4
42 - 3	Washer	A4
43	Hexagon nut	A4
43 - 1	Hexagon nut	A4
940	Feather key	A4

Characteristic curves of the TE series

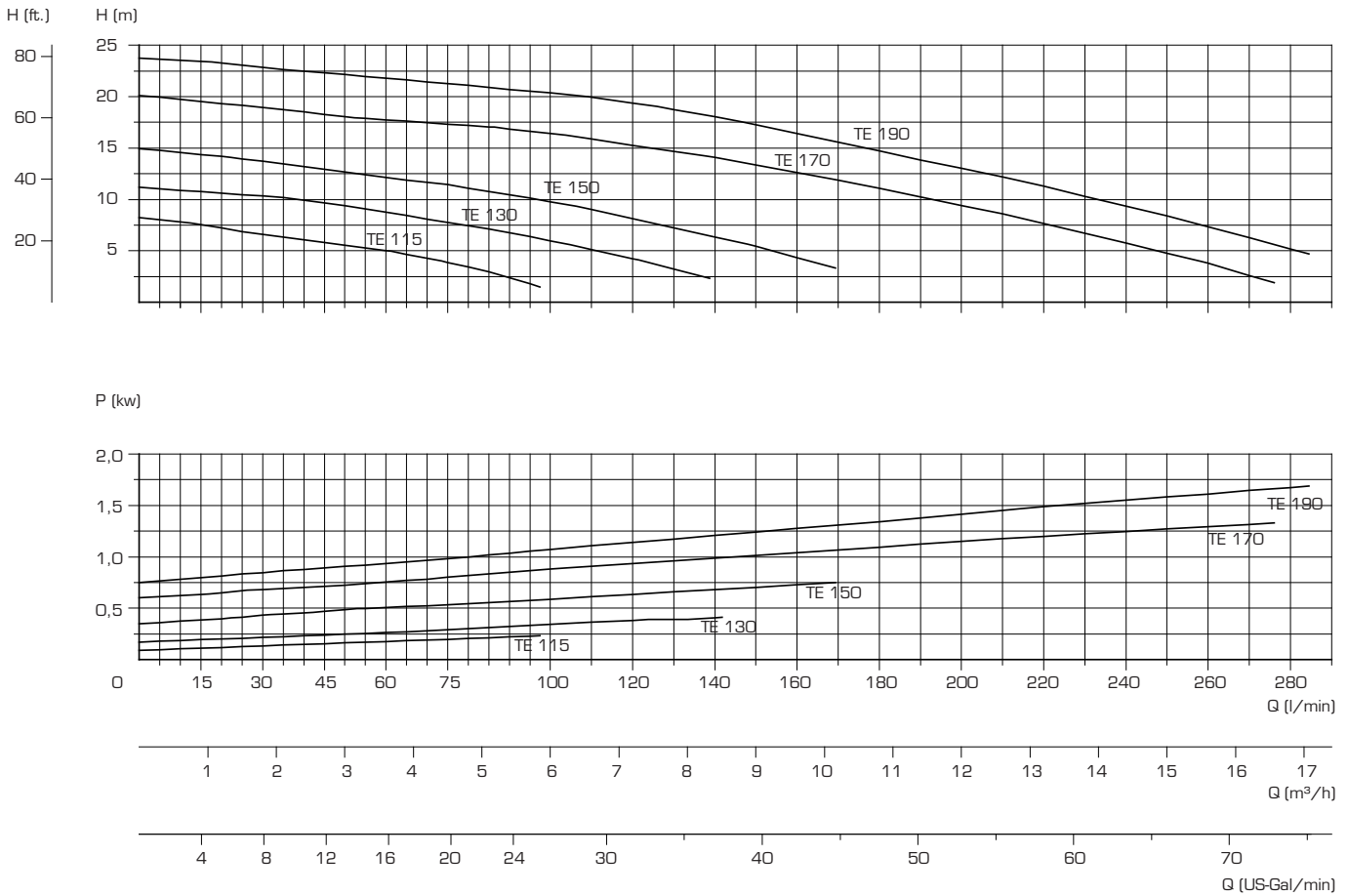

Characteristic curves measured with water at 20°C and 2900 rpm (50 Hz).

Typ	Motor power P	ET = depth of immersion
	kW	mm
T 115	0,25	200 - 300 - 400
T 130	0,55	200 - 300 - 400
T 150	0,75	300 - 400 - 500
T 170	1,50	400 - 600 - 800
T 190	2,20	400 - 600 - 800

Specifications for the TE series

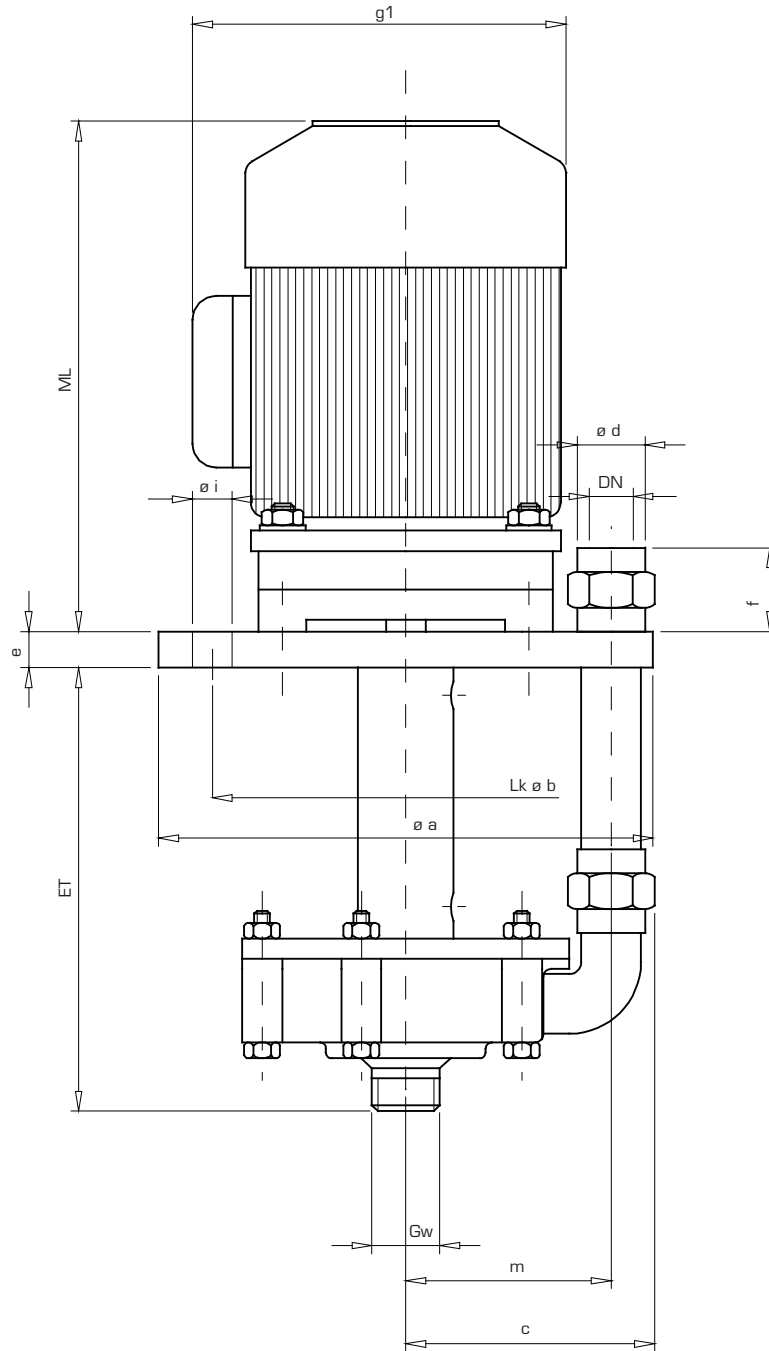

Type	ø a	ø b	c	ø i*	e	f	g1	m	ML	ø d	DN
TE 115	230	170	121	11	15	44	158	97	211	27	25
TE 130	240	200	124	11	15	44	182	100	241	27	25
TE 150	265	225	137	11	15	46	209	113	263	27	25
TE 170	320	280	156	13	15	50	235	130	278	34	32
TE 190	330	280	167	13	15	50	235	141	303	34	32

General

SCHMITT centrifugal pumps comply with the high demands made on them in terms of design and production.

Proper assembly and treatment as recommended in this operating manual are the prerequisites for problem-free long-term operation.

For this reason, this manual must be read carefully before assembly and initial operation of the pumps as well as during servicing work, and the advice it contains must always be followed. Every SCHMITT centrifugal pump has a part number on it with the numbers necessary for any correspondence and reserve deliveries later. Please always quote this number.

Warranty

Warranty is granted according to our General Terms and Conditions.

Always inform us immediately of any damage that occurs during the warranty period, this is the only way you can be sure of making a warranty claim.

We can only accept warranty for the materials and versions recommended if the operating conditions and liquids pumped match the specifications given in the order.

If there are any changes in concentration, temperature of the pumped media or hydraulic data, we have to be consulted. We will then check whether the pump we delivered can be used for the changed operating conditions. In the event of any damage caused by non-observance of this, we cannot accept any liability, as set out in our Terms of Delivery.

Our written agreement has to be obtained for modification and servicing work during the warranty period, as otherwise the warranty shall be null and void.

Only use qualified staff for this work, or return the complete pump to our factory for examination or repair.

We cannot accept warranty for pump parts that are subject to premature wear on account of their material properties or type of use, such as mechanical seals, seals and the like. For accessory parts that we do not manufacture ourselves, we can only accept warranty claims within the scope granted to us by the respective sub-supplier.